

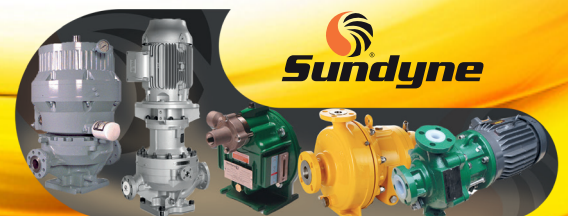

CSA FRAME 1 PUMP RANGE (60HZ)

Magnet Drive end suction centrifugal pumps in accordance to:
ASME B73.3-2015





Introducing HMD

Having pioneered the magnetic drive pump over seventy years ago HMD Kontro have continued to develop the technology. We are proud to offer an extensive range of products and services to satisfy the pumping needs and specific requirements found within the Chemical industry, whilst maintaining our flexible approach and without compromising the quality or reliability of our equipment. The products and services provided by HMD Kontro offer the ultimate solution to:

- **Environmental concerns**
- **Recurring mechanical seal problems**
- **Health and safety concerns**
- **Seal system complexities**
- **Maintenance / downtime reduction**
- **Minimising spare parts inventory**
- **Lowering the cost of ownership**

The chemical industry demands reliability, safety and cost efficiency. The production of chemicals in their various forms leads to great volumes of liquid and other materials being pumped around a plant. Containing these liquids calls for pump systems that can be relied upon to keep hazardous chemicals contained throughout the production process and so, sealless pumps are playing an ever greater part in meeting these challenges. Indeed, in some cases more stringent regulations and local agencies are mandating their use.

Introducing the CSA Range

The CSA magnet drive end suction centrifugal pumps are a modular range of chemical service pumps, designed to cover a wide duty and application base using the minimum of pump models by maximising interchangeability of components.

The range is based on a number of hydraulic sizes and fully conform to the current ASME B73.3 dimensional, performance and construction requirements. Close coupled and separately mounted variants are available.

A wide range of options are available including secondary sealing options and numerous bearing assembly variants. The range is specifically designed for maximum part interchangeability, ease of onsite service and has a wide number of site upgradable features.

Products in the Range

Parameters

Temperatures:	- 40°F to 500°F
Flow Rates to:	340 USgpm
Heads to:	296 ft
Viscosity:	0.1 to 200 cSt
Powers:	40hp
Design Pressures:	275 psi @ 100°F
Solids Capability:	5% w/w <0.006"

CSA (ASME B73.3-2015)

Key Design Features

- **No Seals:** Minimises maintenance, all of the associated costs and eliminates potential leaks.
- **Sealless design:** For total containment, essential for hazardous, aggressive or valuable product.
- **Modular & interchangeable components:** For maximum convenience and minimal lead time.
- **High efficiency hydraulics:** To benefit maximum flow / head coverage.
- **Low and High Flow hydraulic variants:** Provides optimised hydraulic fit.
- **Robust design:** Featuring ZeroLoss® containment shell for tolerance to system upsets.
- **Casing Gasket fully confined:** Eliminating risk of blowout.
- **Internal & External Bump Ring Design:** Providing additional level of robustness.
- **Modular Rotating Element Cartridge:** Providing the most efficient way to perform rapid replacement and manage spare part inventory.

Benefits of CSA Frame 1 Pump Range:

- Sealless design for total product containment
- Ideal for hazardous, toxic, aggressive, hot and valuable product
- Fully Enclosed Magnets
- Modular construction
- Choice of materials of construction
- Site upgradable design features



CSA Pump range

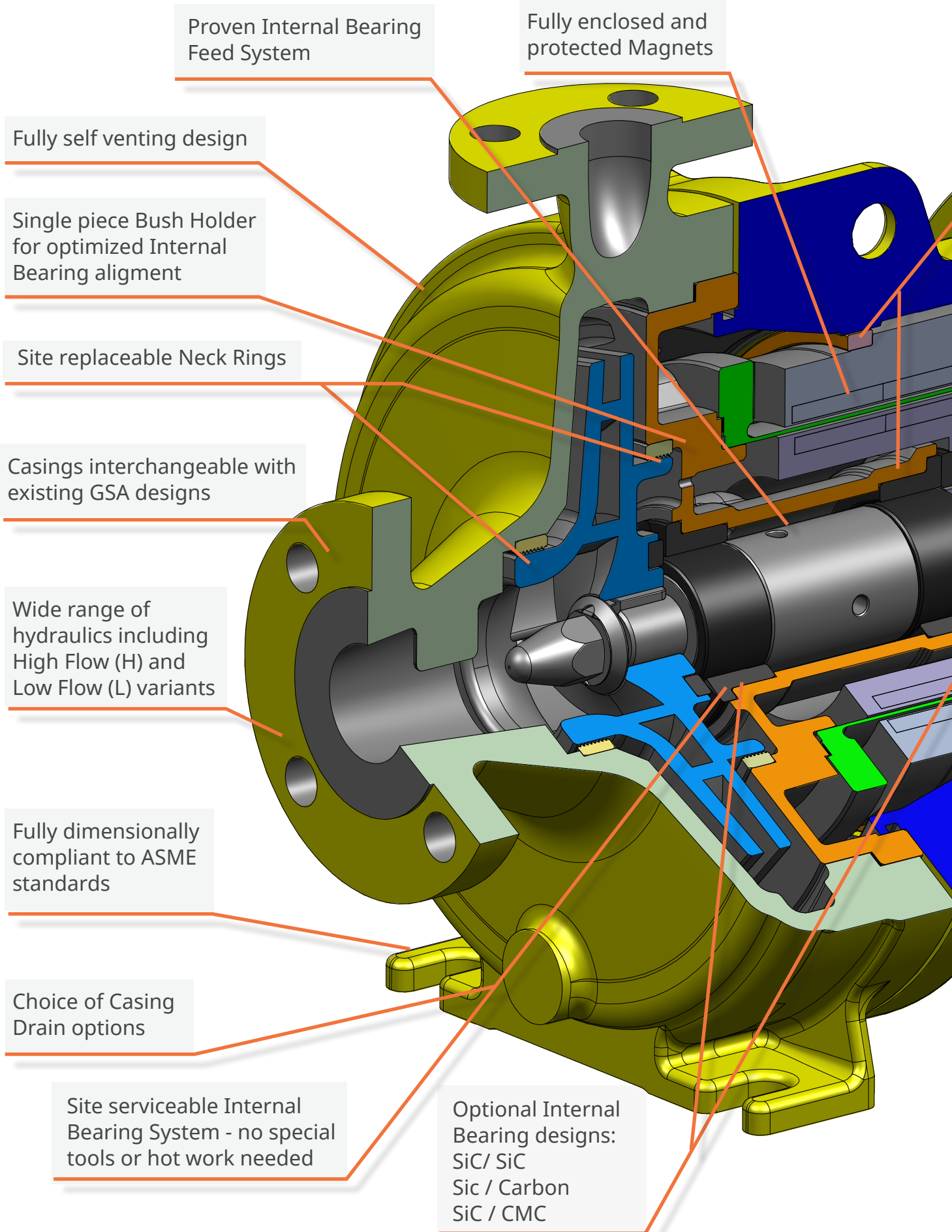

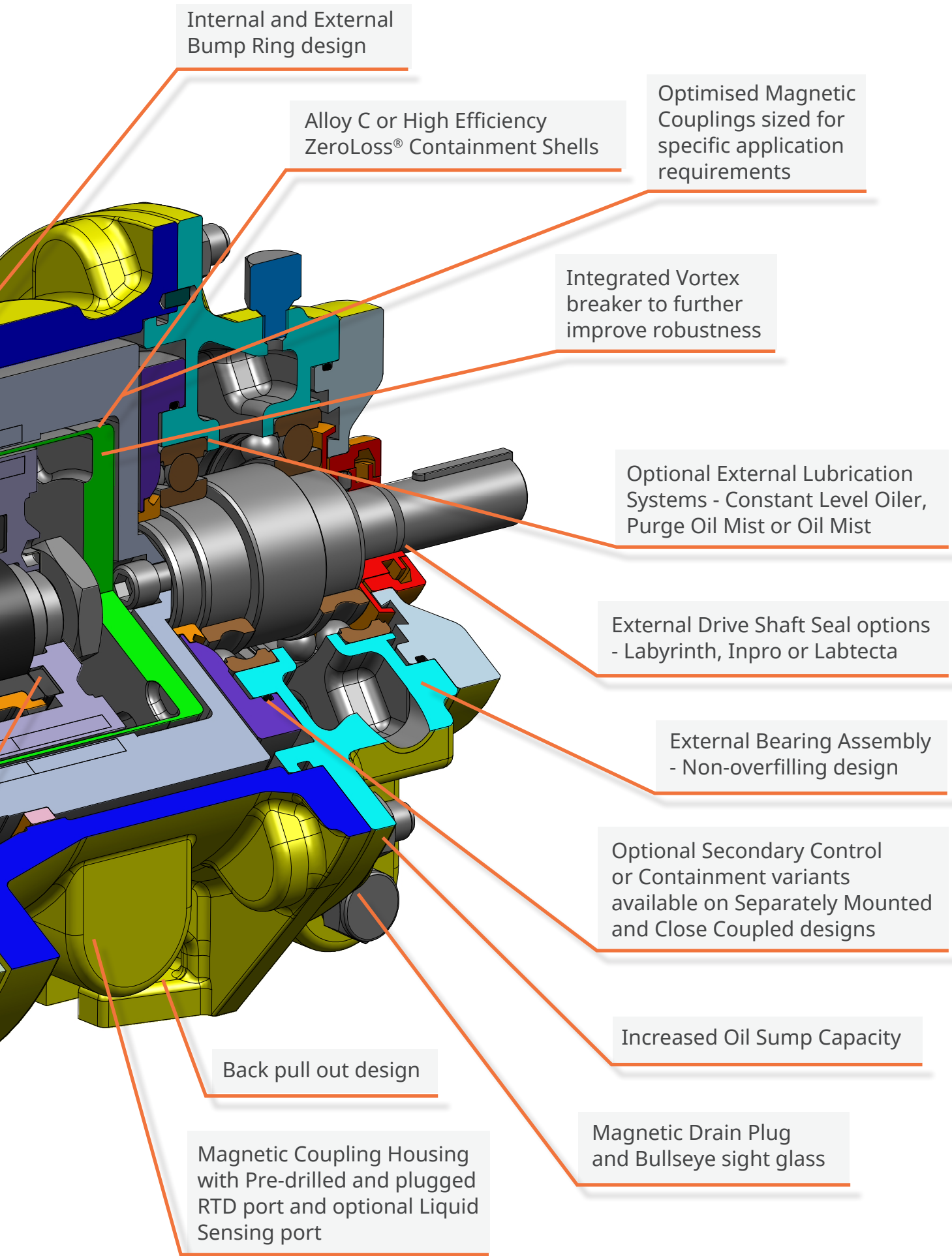

Performance of the CSA Frame 1 Pump Range

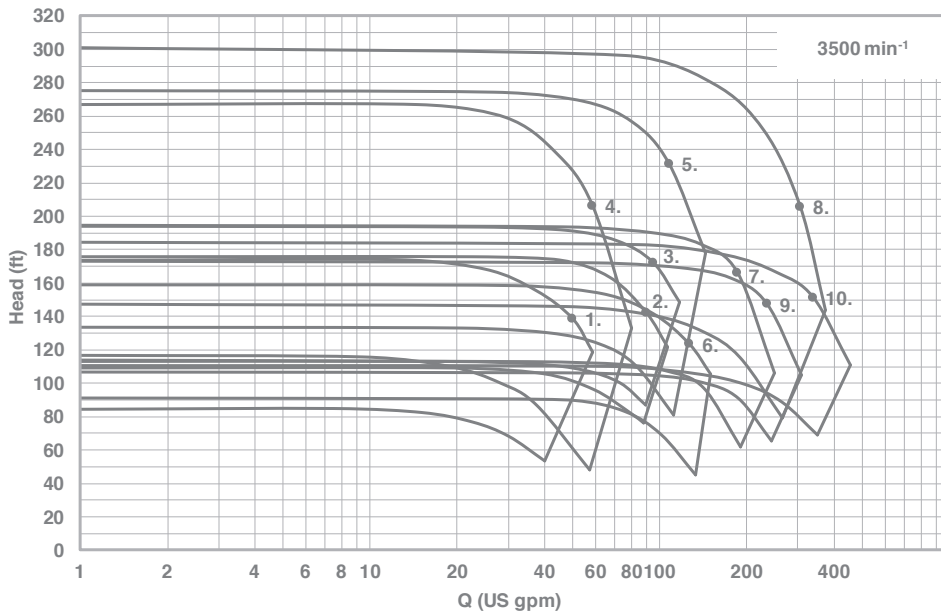

Reference	CSA
1	1.5x1x6-L1
2	1.5x1x6
3	1.5x1x6H
4	1.5x1x8-L1
5	1.5x1x8
6	3x1.5x6
7	3x1.5x6H
8	3x1.5x8H
9	3x2x6
10	3x2x6H

Construction of the CSA Frame 1 Pump

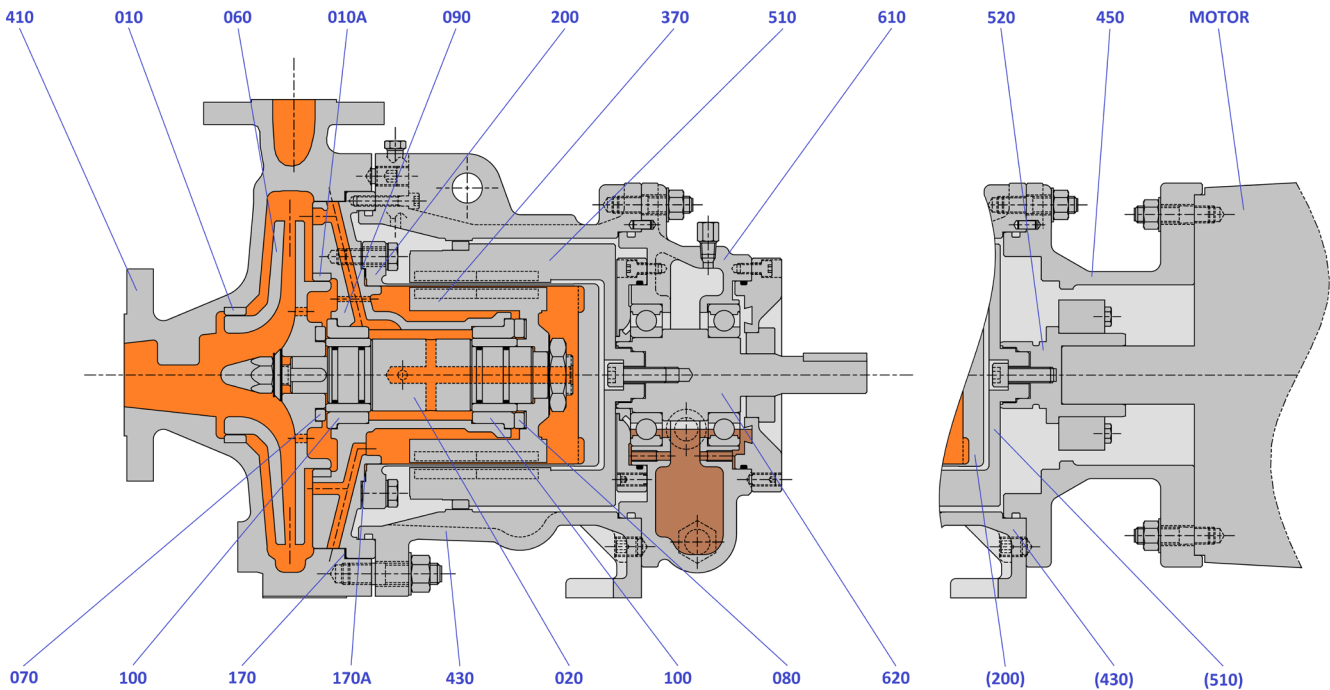

010	Neck Ring (Front)	316L St St
010A	Neck Ring (Back)	316L St St
020	Pump Shaft	316L St St
060	Impeller	316L St St
070	Front Thrust Washer	Silicon Carbide
080	Back Thrust Washer	Silicon Carbide
090	Bush Holder	316L St St
100	Bush	Silicon Carbide
170	Casing Gasket	CSF
170A	Shell Gasket	CSF

200	Containment Shell	Alloy C / 316L
370	Inner Magnet Ring	316L St St Clad
410	Casing	316 St St
430	Coupling Housing	SG Iron
450	Motor Adaptor	SG Iron
510	Outer Magnet Ring	C. Steel (Sheathed)
520	Drive Adaptor	Carbon Steel
610	Bearing Housing	SG Iron
620	Drive Shaft	Carbon Steel

Dimensions of CSA Frame 1 Pump

Separately Mounted (Bareshaft)

Size	All Frame 1
CP	17.5
CPe	19
D	5.25
2E1	6
F	7.25
H	0.625
O	11.75
U	0.875
V	2
X	6.5
Y	4

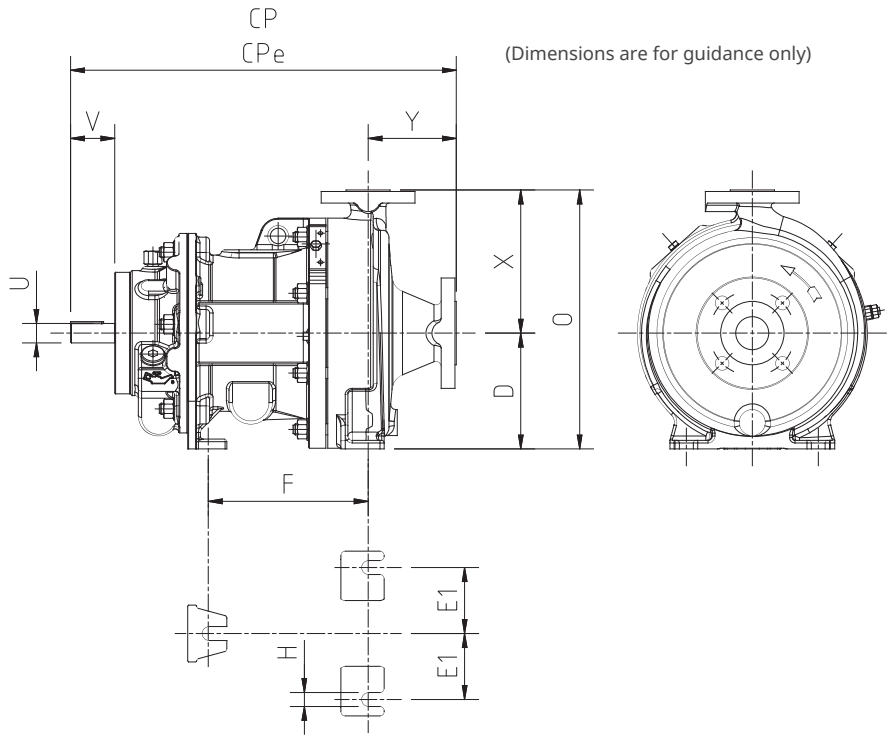

Separately Mounted

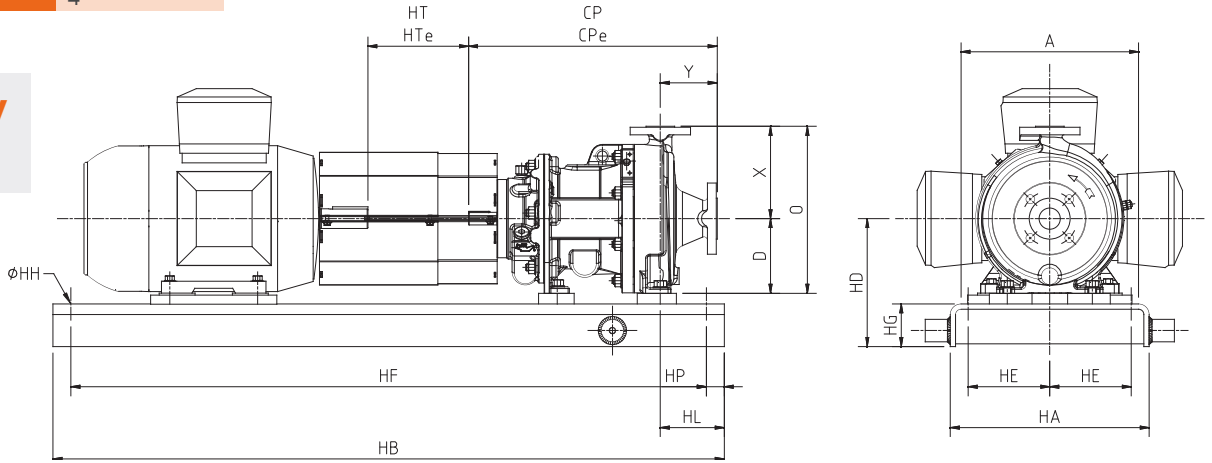

Motor Frame	A	HA	HB	HT	HTe	HD	HE	HF	HG	HH	HL	HP
143TC - 184TC	12	14	43	5.5	4	9	4.5	40.5	3	0.75	4.5	1.25
213TC - 256TC	15	17	52	5.5	4	10.5	6	49.5	3.5	0.75	4.5	1.25
284TSC - 326TC	18	20	57	5.5	4	12.5	7.5	54.5	4	0.75	4.5	1.25

Close Coupled

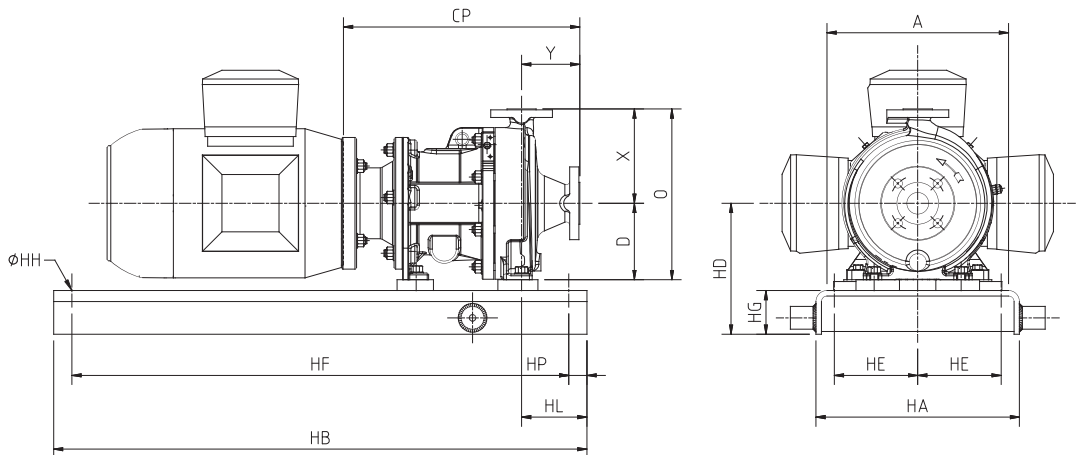

Motor Frame	CP	A	HA	HB	HD	HE	HF	HG	HH	HL	HP
143TC - 145TC	15.14	12	14	32	9	4.5	29.5	3	0.75	4.5	1.25
182TC - 184TC	15.65	12	14	32	9	4.5	29.5	3	0.75	4.5	1.25
213TC - 215TC	16.17	15	17	41	10.5	6	38.5	3.5	0.75	4.5	1.25
254TC - 256TC	16.80	15	17	41	10.5	6	38.5	3.5	0.75	4.5	1.25
284TSC - 286TSC	16.05	18	20	44	12.5	7.5	41.5	4	0.75	4.5	1.25

Metallic and ZeroLoss® shell options

- interchangeable

ZeroLoss® Shell

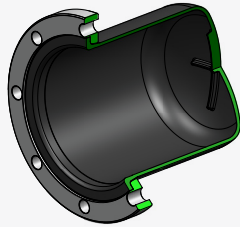

- 275 psi Design pressure
- PEEK Composite design
- Suitable for process temperatures up to 250°F
- High Power NdFeB Magnetic Coupling
- High efficiency – no induction losses, no heat into process liquid
- Provides highest process upset tolerance
- In-built vortex breaker

Metallic Shell

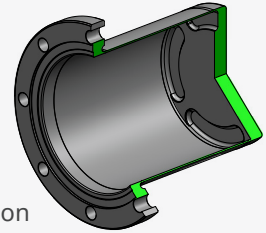

- 275 psi Design pressure
- Proven welded construction
- High strength alloy C276 tube
- Suitable for process temperatures up to 500°F
- Range of SmCo Magnetic Couplings to suit specific duty requirements
- In-built vortex breaker

Site Serviceable Design

Site replaceable Cartridge design ensures maximum up time and minimum disruption in the unlikely event of a breakdown.

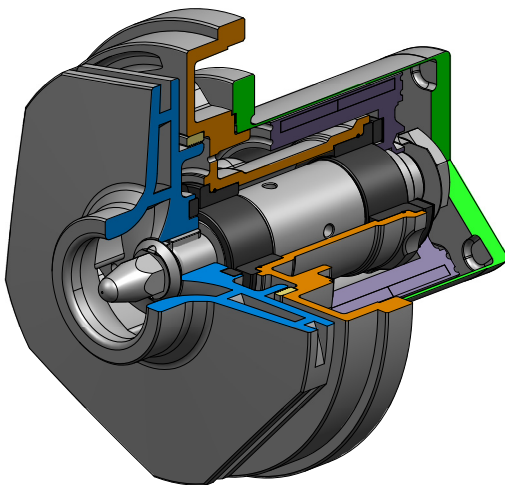

Comprising of wetted parts (not casing):

- Impeller
- Shaft
- Internal Bush Holder and Bearings
- Containment Shell
- Inner Rotor

Designed to be serviced / overhauled on site:

- No special tools
- No hot working
- Simple to decontaminate
- No special motor decontamination needed

Site serviceable Internal Product Lubricated Bearing assembly:

Single piece Bush Holder – easily serviced on site:

- No hot working
- No special tools
- In built bush retention features

Radial and Thrust Bearings interchangeable across entire Frame 1 range

Optional Internal Bearing Materials

- SiC vs Sic (Standard Build)
- SiC vs Carbon (Variant for low lubricity conditions)
- SiC vs Ceramic Matrix Composite (CMC) thrust bearing (Variant for marginal applications)

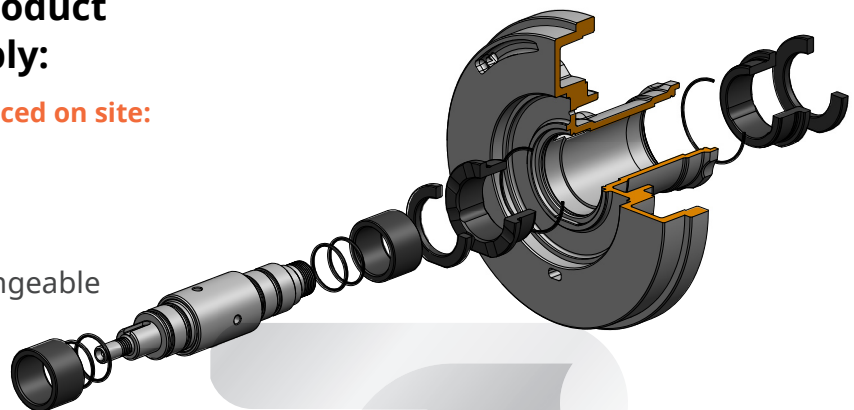

External Bearing Assembly

Extended Spacer and Shaft design for increased process temperatures from 400°F to 500°F.

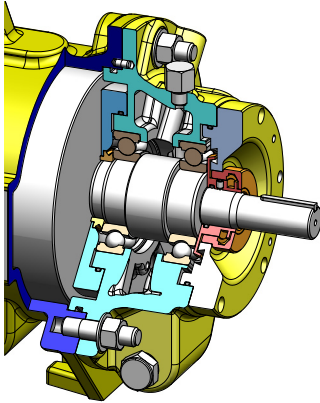

Standard design

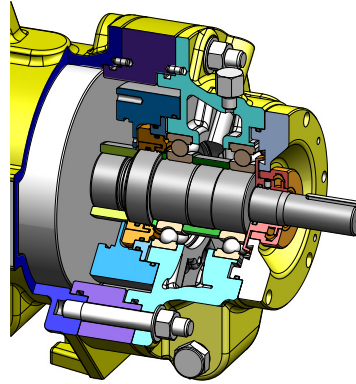

Extended CPe design

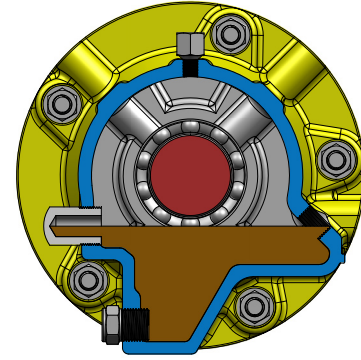

Non-overfilling design

External bearing assembly:

- Non-overfilling design
- Large sump capacity
- Magnetic sump plug
- Bulls eye style sight glass
- External bearing isolator options available

Available lubrication systems:

- Oil bath (standard)
- Oil bath and constant level oiler
- Purge Oil mist
- Pure Oil mist

Additional Security

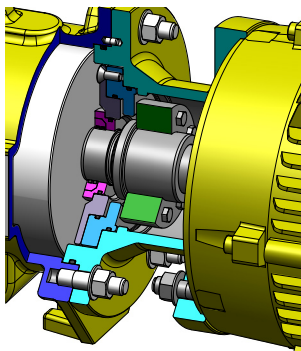

Close Coupled
Secondary Control

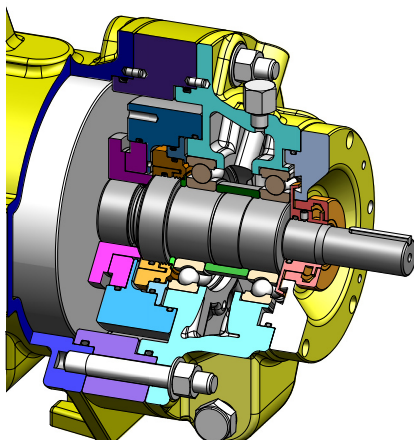

Separately Mounted
Secondary Containment

...designed for maximum service life and ease of maintenance

Secondary Control and Containment Options:

- Choice of secondary control or secondary containment systems
- Secondary housing designed for 275 psi pressure conditions
- O-rings to completely seal secondary housing
- Provision for Liquid Sensing probe or Pressure Sensing device to be fitted in Secondary housing
- Fully compliant to ASME requirements
- Available on both Close Coupled and Separately Mounted design configurations
- Extended Spacer and Shaft design utilised on Separately Mounted designs
- For process temperatures < 400°F

...when product integrity cannot be compromised

Pump End Interchangeability Matrix

SIZE	K3 1.5x1.6L	K1 1.5x1.6	K1H 1.5x1.6H	K2 3x1.5x6	K2H 3x1.5x6H	K4 3x2x6	K4H 3x2x6H	K6 1.5x1x8L	K5 1.5x1x8	K7H 3x1.5x8H
CASING & IMPELLER										
PUMP SHAFT	STANDARD									
BUSH HOLDER	STANDARD									
PRIMARY CONTAINMENT GASKETS	STANDARD					CASING & CONTAINMENT SHELL				
INNER MAGNETIC RING										
CONTAINMENT SHELL										
OUTER MAGNETIC RING										
SECONDARY CONTROL / SECONDARY CONTAINMENT	NO					YES				
COUPLING HOUSING										
DRIVE END OPTIONS	REFER TO CLOSE COUPLED DRIVE END MATRIX					REFER TO SEPARATE MOUNTED DRIVE END MATRIX				

PUMP END MATRIX

Drive End Interchangeability Matrix

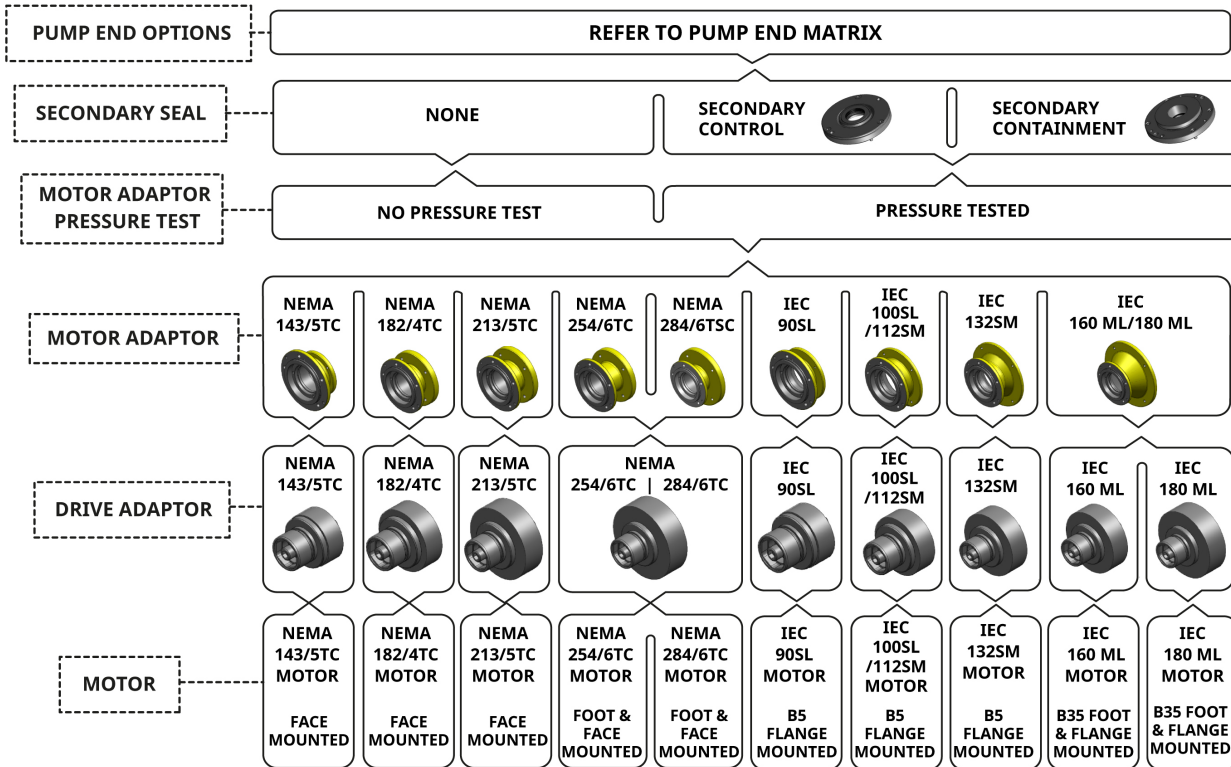

CLOSE COUPLED DRIVE END MATRIX

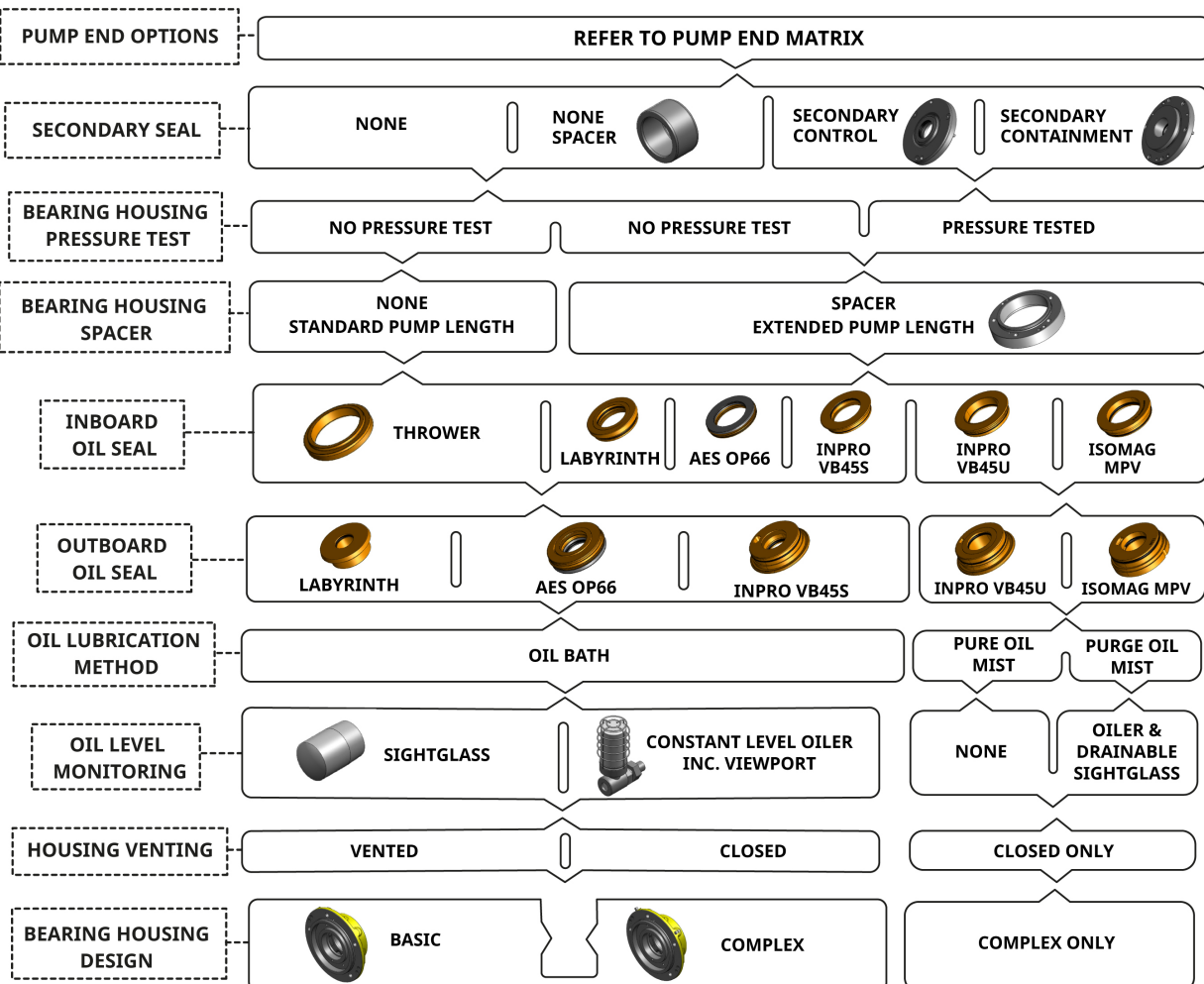

SEPARATE MOUNTED DRIVE END MATRIX

Flanges and Connections

Casing

Suction and discharge flanges are designed in accordance with the following standards:

ASME B16.5 Class 150lb Machined with 0.06" high raised face having a continuous spiral groove

Flange Loadings

Allowable flange loadings imposed by the pipework are in accordance with ANSI/HI 9.6.2.



Options

A wide variety of options are available:

Materials of Construction:

316L Stainless Steel (standard)
Alloy C (optional variant)
Alloy 20 (optional variant)

Containment Shells:

Metallic Construction (- 40°F to 500°F)
High Efficiency ZeroLoss® PEEK (- 40°F to 250°F)

Internal Bearings:

Silicon Carbide vs Silicon Carbide (standard)
Carbon vs Silicon Carbide (optional)
Silicon Carbide vs CMC (optional)

Casings Drain:

No Drain or 1/2" NPT Plugged

Gaskets:

Compressed Synthetic Fibre, PTFE or Graphite

Mounting Configuration:

Close Coupled:
(NEMA C-Face or C-Face/Foot Flange Mounted Motor)

Separately Mounted:
(NEMA Foot Mounted Motor and Flexible Coupling)

Constructional Variants:

Secondary Containment
Secondary Control
Oil Bath / Oil Mist Lubrication of external bearing assembly
400 - 500°F Thermal Break

Instrumentation:

Power Sensing, Temperature Sensing and VapourView®

Instrumentation and Protection

It is recommended that magnetic drive pumps are installed with one or more of the following instrumentation options:

- **Power Control Monitor**
- **Temperature measurement of the containment shell**

Provision for VapourView® is also included.

For pumps supplied with Secondary Sealing systems, the following instruments should be considered to detect leakage in the secondary pressure housing:

- **Liquid sensing probe**
- **Pressure sensing device**

It should be noted that both should be set to stop the pump immediately if the presence of process liquid is detected.

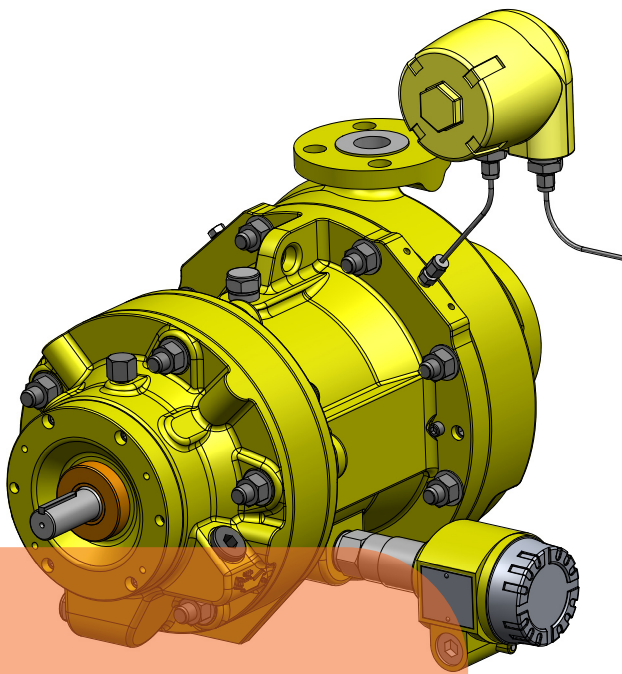
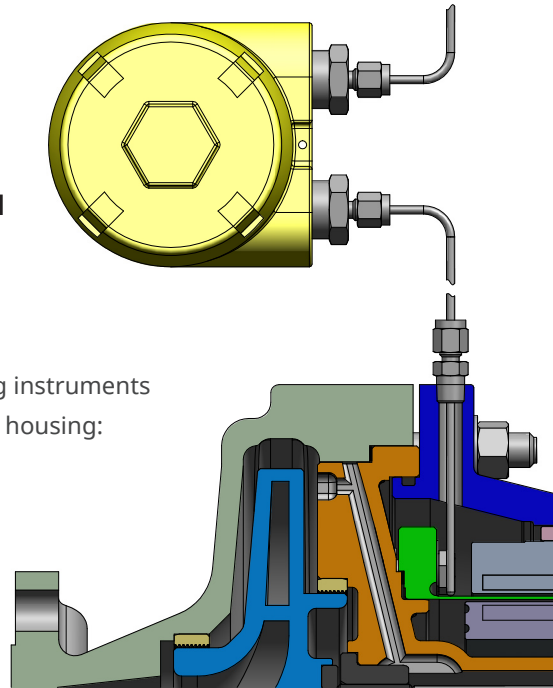

In situ site upgrade options

The CSA pump has been specifically designed to allow onsite changes/upgrades to be carried out with ease. All require only standard tools and no hot working:

- Conversion between Close Coupled and Separately Mounted configurations
- Lubrication type of the external bearing assembly
 - Oil Bath / Purge Oil Mist / Purge Oil Mist
- Upgrades to the external bearing assembly seals
 - A number of proprietary seal options are available
- Change to ZL magnetic coupling and containment shell
- Upgrade of CC or SM pumps to feature secondary control or containment

Value Proposition

HMD Kontro high quality Sealless Pumps move hazardous and high value liquids with simplicity and in complete safety whilst ensuring maximum production output and profitability.

THINK SEALLESS



"We find HMD Kontro pumps last over 20 years but sealed pumps need to be replaced in 10 or 12 years."
Pharmaceutical manufacturer

Sealless pumps are easy to maintain, have few working parts, no potential leak paths and no support systems to design, install and maintain. When selecting a sealless pump over a mechanical sealed pump it doesn't just come just down to the long term cost benefits. The sealless technology is by design, the right choice for situations involving high temperatures, high viscosity, high pressures and volatile substances for many more reasons than just the lifetime cost.



SEALLESS SYSTEM

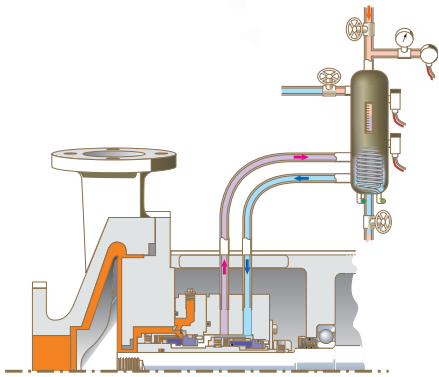

What is a sealless magnetic drive pump?

A sealless pump is essentially a conventional centrifugal pump without packed glands or mechanical seals. The dynamic seal that would normally be used to seal the impeller shaft is instead replaced by a static containment shell -- or shroud -- to form a completely sealed liquid end or pressure boundary.

Why are they sealless?

Mechanical seals are widely regarded as the weakest point in any pumping system using them, according to a report by the UK Health and Safety Executive, they account for 80% of all pump failures, the remainder being leakage through static seals such as gaskets / O rings and bearing failure. It follows that if you eliminate the problem, you eliminate the failures and save costs.

Sealless pumps don't leak, meaning that they can help reduce process inefficiencies, maximize output and minimize the risks posed to your process environment by hazardous and volatile materials.



SEALLESS SELECT

For situations involving high temperatures, high viscosity, high pressures and volatile substances, sealless magnetic drive pumps are the clear choice. Specifically, when it comes to applications that involve toxic, fine, corrosive and aggressive liquids that must be handled, our sealless magnetic drive pumps deliver the rock solid performance that engineers demand and that industrial regulations require.



- **Chemical**
- **Pharmaceutical**
- **Fine chemical**
- **Agrichemical**
- **Oil & Gas (upstream and downstream offshore and onshore)**
- **Food & beverage production**
- **And across many industrial operations**

Typical applications are for fluids presenting difficult and/or costly sealing challenges:

- Acids
- Solvents
- High melting point liquids
- Heat transfer fluids
- Volatile liquids - LPG, Processed hydrocarbons, Crude oil
- Hazardous liquids
- Expensive fluids
- Fluids under pressure
- Toxic
- Pungent
- Corrosive
- Radioactive
- Crystallising

The latest parameters at which magnetic drive pumps can operate may surprise you:

- Temperature - Down to minus 112°F / 80°C
- Up to 840°F / 450°C Torque Ring Design
- Up to 600°F / 315°C Synchronous Design
- Flow Rates – Up to 690m³/hr / 3000 USgpm
- Heads – Up to 240m / 767 ft differential
- Viscosity – Maximum 200 cSt
- Pressure - Up to 2683 psi / 185 Bar
- Solids - 150 micron / 0.006"
- Up to 8% - 250 micron / 0.010"
- Power - 530hp 60hz / 400kW 50hz
- Speed Range 1450 – 3500 RPM

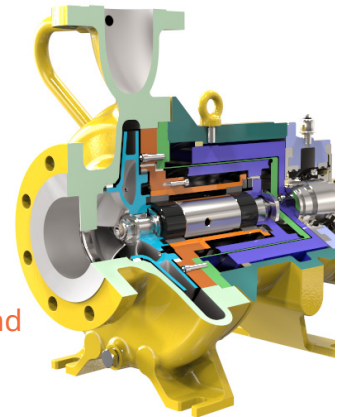

SEALLESS SERVICING

Thanks to a modular construction and the ability to dismantle HMD Kontro sealless pumps without special tools, servicing and maintenance of the pumps on site is simple and straightforward.

- | | |
|---|---|
| <ul style="list-style-type: none"> • Simple design • Minimal maintenance skills required • No complex seals or sealing systems • No special tools | <ul style="list-style-type: none"> • Site repairable • Cartridge design means minimum spares • Cartridge replacement: Only basic tools needed (spanner & hex key) Time: 20 minutes • No need for vibration monitoring |
|---|---|

The modular construction and common componentry, for example cartridges, means less spare parts stock and inventory for reduced operational costs



SEALLESS SAVINGS

The adoption of sealless pumps can achieve the step change savings that are needed from concept to completion of your project and beyond, throughout the life of the pump.



SEALLESS SOLUTION

Combining cutting edge technology with over seventy years of expertise and experience, since we were the first in the world to develop the concept, sealless pumps provide complete peace of mind.

- | | | |
|---|---|---|
| <ul style="list-style-type: none"> • No Seals • No Seal Support Systems • No Risk of Seal Failure • No Leaks (At All!) • No Emissions | <ul style="list-style-type: none"> • No Environmental Hazards • No Health Issues • No Safety Concerns • No Maintenance (Almost!) • No Buffer or Flush Fluid Costs | <ul style="list-style-type: none"> • No Need to Decontaminate • No Loss of Product • No Loss of Production Output • No Unexpected Expenses • No Problems! |
|---|---|---|

Sealless Service

Although our pumps only require minimal maintenance, that does not mean there is no after sales service from HMD Kontro. Quite the opposite in fact.

Our own After Sales team, together with our channel partners around the world, can help to optimise the performance and through life experience of using HMD Kontro pumps. From assisting with installation and commissioning, including ensuring smooth contract execution and swift provision of all the appropriate documentation, through to optimising your spares inventory and operating efficiency using the benefit of our experience.

Extending MTBF (mean time between failure) and providing you with the appropriate parts to effect fast maintenance and quick replacement where necessary, will significantly assist in reducing downtime and minimising through life costs, which are already inherently low with an HMD Kontro pump.

To learn more about why sealless is so suitable for your application, please contact us, either directly or through your country partner, details of which can be found on www.sundyne.com. We look forward to helping sealless be of service to you.

www.hmdkontro.com

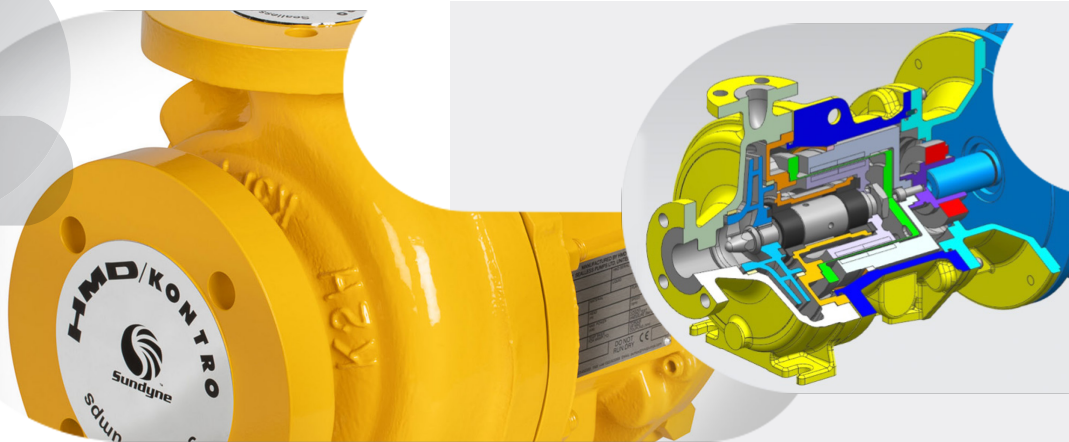

HMD Kontro Sealless Pumps

Marshall Road
Hampden Park Industrial Estate
Eastbourne, East Sussex, BN22 9AN
United Kingdom
Phone: +44 (0)1323 452000
Email: hmdpumps@sundyne.com
www.hmdkontro.com

Sundyne Headquarters
Sundyne LLC
14845 West 64th Avenue
Arvada, Colorado 80007
USA
1-866-Sundyne
Phone: 1 303 425 0800
www.sundyne.com

Sundyne France
Sundyne International S.A
13-15, Bld, Eiffel - B.P. 30
21604 Longvic Cedex
France
Phone: +33 (0)3 80 38 33 00

Sundyne Spain
Sundyne Marelli Bombas, S.R.L.
Ctra, Madrid-Toledo, Km. 30.8
45200 Illescas
Toledo, Spain
Phone: +34 925 53 45 00

All information provided is subject to change without notice.

© 2014 Sundyne, LLC
All Rights Reserved. Other logos and trademark names are property of the respective owners.

HMD Kontro
CSA Frame 1 Pump Range (60HZ)
ASME B73.3-2015

CSA Frame 1 60Hz Brochure 1.1 3/20 AM.

