

## Technical Profile

### GSA/GSI frame 0

Magnet drive, end suction, centrifugal pumps to ISO 2858 / DIN. EN 22858:1993 / ASME B73.3

A versatile range of general service pumps designed to cover a wide duty and application base using the minimum of pump models by maximising interchangeability of components. Available within the range is the GSA (ASME standard pump) and the GSI (ISO DIN standard pump). A GSL option is available for temperatures down to -100°C / -150°F.

The GSA (ASME) and GSI (ISO) product covers a hydraulic range that is split between three frame sizes, Frames 0, I, & II. The pumps are offered with a range of Synchronous Magnet Drives rated to match prime mover performance, hence specifications of all denominations can be catered for.

This range is based on sizes conforming to ASME & ISO performance and dimensional standards.

The standard materials of construction are Stainless Steel with silicon carbide internal bearings.

### HMD Kontro



### Performance of the GSA/GSI frame 0

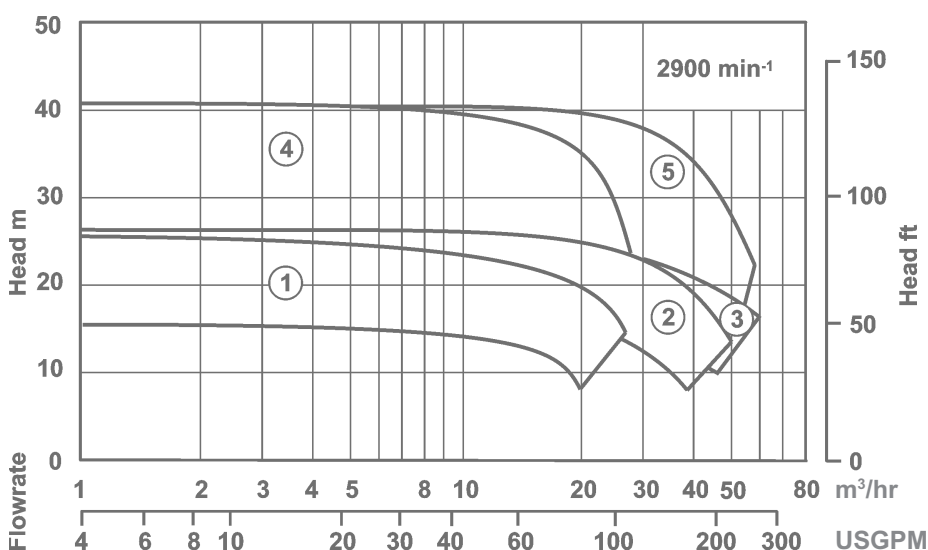

### Pump model

	GSA	GSI	GSA	GSI
1	1.5 x 1 x 5	50-32-125	4	1.5 x 1 x 6H*
2	3 x 1.5 x 5	65-50-125	5	3 x 1.5 x 6H
3	3 x 2 x 5	80-65-125		

\* Includes low flow hydraulic options

### Design range limits

The GSA/GSI pump is designed to operate from -40°C up to 260°C / -40°F up to 500°F without the need for any ancillary cooling medium. Design working pressure is 18.9 bar / 275 psi.

### Solids handling capability

The unit is capable of handling solids up to 5% w/w less than 150 microns.

### Options

#### Materials of construction

Wetted parts Alloy 20, Alloy C, Alloy B  
Internal bearings SiC / Carbon  
Gaskets PTFE

#### Other options

Casing drains flanged or screwed  
Jacketed pump casing  
Coupling housing drain  
Large range of pump protection

## Key Design Features

- **No seals:** To minimise maintenance, all of the associated costs and eliminate potential leaks.
- **Sealless design:** For total containment, essential for hazardous, aggressive or valuable product.
- **Interchangeability of components:** For maximum convenience and reduced stock holding, operator training etc.
- **High efficiency wet end:** To benefit maximum flow / head coverage.
- **Wide choice of materials:** To allow a choice metallurgy to suit the application requirements.
- **Casing gasket fully confined:** So eliminating risk of blowout.
- **Universal connection options:** So that suction and discharge flange connections can be configured to your exact requirements.
- **Modular rotating element cartridge:** Providing the most efficient way to perform replacements and manage your spare part inventory.

## Benefits of GSA/GSI pump range:

- Sealless design for total product containment.
- Ideal for hydrocarbon, toxic, aggressive, hot and valuable product.
- Conforms to ASME and ISO standards.
- Modular high efficiency wet ends.
- Designed to ensure maximum flow/head coverage across all ranges.
- Choice of various metallic materials of construction.
- One fully confined casing / containment shroud / shell joint.

## Construction of GSA/GSI frame 0

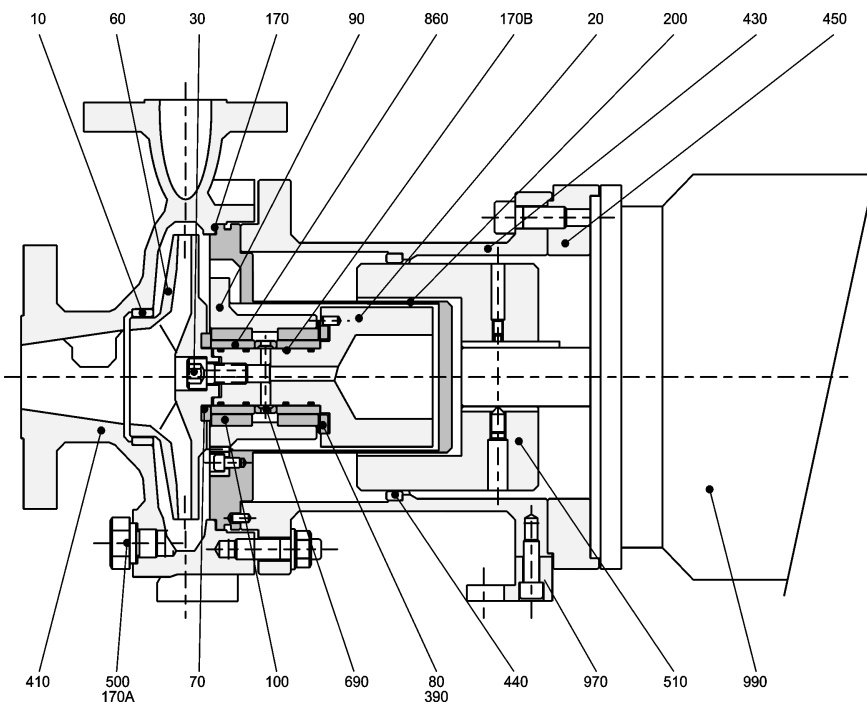

10	Front Neck Ring	Stainless Steel
20	Pump Shaft/IMR	Stainless Steel
30	Impeller Fixing	Stainless Steel
60	Impeller	Stainless Steel
70	Front Thrust Washer	Alpha SiC
80	Back Thrust Washer	Alpha SiC
90	Bush Holder	Stainless Steel
100	Bush	Alpha SiC
170	Gasket (Casing)	CSF / PTFE
170A	Gasket (Drain)C	CSF / PTFE
170B	O' Ring	Viton A / PFR
200	Containment Shroud/Shell	Stainless Steel/C276
390	Support Gasket	Exfoliated Graphite & SS
410	Casing	Stainless Steel
430	Coupling Housing	SG Iron
440	Bump Ring	Phosphor Bronze
450	Motor Adaptor	Carbon Steel
500	Drain Plug	Stainless Steel
510	Outer Magnet Ring	Carbon Steel
690	Shaft Sleeve Spacer	Stainless Steel
860	Shaft Sleeve	Alpha SiC
970	Coupling Housing Foot	SG Iron
990	Electric Motor	Proprietary

## Flanges and Connections

### Casing

Suction and discharge flanges are designed in accordance with the following relevant standards:

#### ASME B16.5 Class 150 + 300

Machined with 1.5 mm (0.06") high raised face having a continuous spiral groove.

#### BS 4504 PN16 + PN40

Machined with 1.5mm (0.06") high raised face having a continuous spiral groove.

#### DIN 2543/2545 PN16 + PN40

Machined with a 2mm high raised face with a continuous spiral groove. (Note: these flanges are identical to BS4504 PN40.)

### Flange Loadings

Allowable flange loadings imposed by pipework are in accordance with Table 4 of API 685 2nd edition and exceed the values in ISO 5199 Annex C.

### Drain Connections

The following drain options are available:

**Standard:** 3/8" BSP drain plug fitted with fully trapped gaskets.

**Option 1:** No drain, boss left undrilled.

**Option 2:** 1/2" NPT plug.

**Option 3:** 1/2" flange rated to the casing flanges.

### Gauge Connections:

Connection of pressure gauges at the suction and discharge branches is possible. The connections are not drilled.

# Dimensions of GSA/GSI frame 0

Dimensions are for guidance only

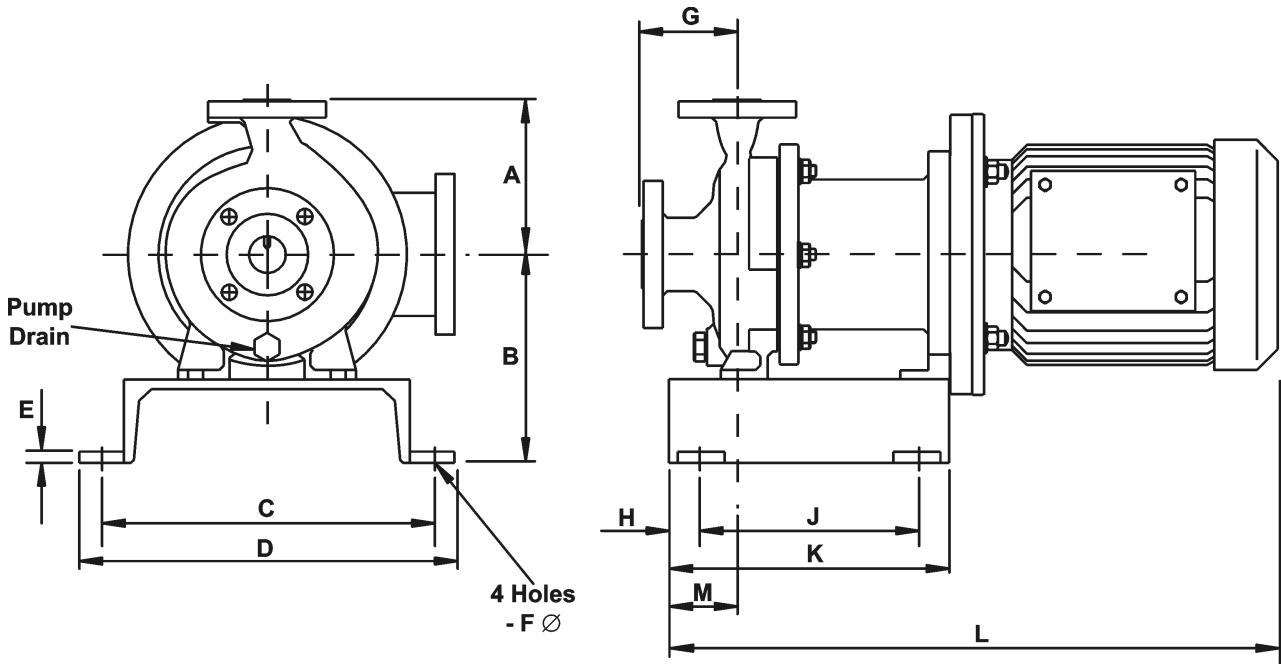

## GSA frame 0

Pump size	A	B	C	D	E	F	G	H	J	K	M	Motor Frame	L
1.5x1x5	165/6.5"	222.5/8.75"	350/13.8"	400/15.75"	12/0.5"	14/0.55"	101.6/4"	34.5/1.4"	230/9"	306/12"	73/2.9"	80-90	631/25"
3x1.5x5	165/6.5"	222.5/8.75"	350/13.8"	400/15.75"	12/0.5"	14/0.55"	101.6/4"	34.5/1.4"	230/9"	306/12"	73/2.9"	100-112	696/27.5"
3x2x5	165/6.5"	222.5/8.75"	350/13.8"	400/15.75"	12/0.5"	14/0.55"	101.6/4"	34.5/1.4"	230/9"	306/12"	73/2.9"	132	784/31"
1.5x1x6H*	165/6.5"	222.5/8.75"	350/13.8"	400/15.75"	12/0.5"	14/0.55"	101.6/4"	34.5/1.4"	230/9"	306/12"	73/2.9"	160	930/36.5"
3x1.5x6H	165/6.5"	222.5/8.75"	350/13.8"	400/15.75"	12/0.5"	14/0.55"	101.6/4"	34.5/1.4"	230/9"	306/12"	73/2.9"	143-145	630/25"
												182-184	679/26.7"
												213-215	783/31"
												254-256	921/36"

\* Includes low flow hydraulic options.

## GSI frame 0

Pump size	A	B	C	D	E	F	G	H	J	K	M	Motor Frame	L
50-32-125	140/5.5"	221/8.7"	350/13.8"	400/15.75"	12/0.5"	14/0.55"	80.31"	34.5/1.4"	230/9"	306/12"	73/2.9"	80-90	529/20.8"
65-50-125	140/5.5"	221/8.7"	350/13.8"	400/15.75"	12/0.5"	14/0.55"	80/3.1"	34.5/1.4"	230/9"	306/12"	73/2.9"	100-112	594/23.4"
80-65-125	140/5.5"	221/8.7"	350/13.8"	400/15.75"	12/0.5"	14/0.55"	100/3.9"	34.5/1.4"	230/9"	306/12"	73/2.9"	132	681/26.8"
50-32-160H	160/6.3"	221/8.7"	350/13.8"	400/15.75"	12/0.5"	14/0.55"	80/3.1"	34.5/1.4"	230/9"	306/12"	73/2.9"	160	827/32.5"
65-50-160H	160/6.3"	221/8.7"	350/13.8"	400/15.75"	12/0.5"	14/0.55"	80/3.1"	34.5/1.4"	230/9"	306/12"	73/2.9"		

Dimensions shown are metric (mm) / imperial (inches).

## Range capabilities

Model	Head	Flow	Design Temperature	Design Pressure	Viscosity cSt	Mounting
GSA 0	41 m 134 ft	60 m <sup>3</sup> /h 264 USgpm	-40 to 260°C -40 to 500°F	18.9 bar 275 psi	200	Separate Mounted (SM)
GSI 0	41 m 134 ft	60 m <sup>3</sup> /h 264 USgpm	-40 to 260°C -40 to 500°F	16 bar 232 psi	200	Separate Mounted (SM)

## Pressure Limits

All parts are to be rated to the pressures shown below at 38°C / 100°F

Flange standard	Design pressure		
	316 St St	Alloy 20	Alloy C
ASME B16.5 Class 150 + 300	1.89 MPa 275 psi	1.59 MPa 230 psi	2.0 MPa 290 psi
BS 4504 PN16	1.6 MPa 232 psi	1.52 MPa 220 psi	1.6 MPa 232 psi
DIN 2543 PN16 + PN40	1.6 MPa 232 psi	1.52 MPa 220 psi	1.6 MPa 232 psi

Component	Hydrostatic test values		
	316 St St	Alloy 20	Alloy C
Casing (ASME 150 + 300lb)	2.93 MPa 425 psi	2.41 MPa 350 psi	3.1 MPa 450 psi
Casing (PN16 + PN40)	2.40 MPa 348 psi	2.3 MPa 325 psi	2.4 MPa 348 psi
Containment Shroud /Shell	2.93 MPa 425 psi	2.41 MPa 350 psi	3.1 MPa 450 psi

## Temperature limits

Standard Range	-40°C to 205°C / -40°F to 400°F
Option	-10°C to 260°C / 14°F to 500°F

For sub zero temperatures a suitable sealing compound (Loctite Multi Gasket or similar) is used to prevent the ingress of moisture into the coupling housing between the containment shroud/shell and motor adaptor assembly interface.

Sundyne Headquarters:

### Sundyne, LLC

14845 West 64th Avenue  
Arvada, Colorado 80007  
USA  
1-866-Sundyne  
Phone: 1 303 425 0800  
Fax: 1 303 940 2911  
www.sundyne.com

Sundyne United Kingdom:

### Sundyne HMD Kontro Sealless Pumps

Marshall Road  
Hampden Park Industrial Estate  
Eastbourne, East Sussex, BN22 9AN  
United Kingdom  
Phone: +44 (0)1323 452000  
Fax: +44 (0)1323 503369

Sundyne China:

### Sundyne Industrial Equipment (Tianjin) Company Limited

Building 1, No. 879 Shen Fu Road  
XinZhuang Industrial Zone  
Min Hang District  
Shanghai, China 201108  
Phone: +86 21 5055 5005  
Fax: +86 21 5442 5265

Sundyne France:

### Sundyne International S.A.

13-15, Bld. Eiffel - B.P. 30  
21604 Longvic Cedex  
France  
Phone: +33 (0)3 80 38 33 00  
Fax: +33 (0)3 80 38 33 66

Sundyne Spain:

### Sundyne Marelli Bombas, S.R.L.

Ctra. Madrid-Toledo, Km.30.8  
45200 Illescas  
Toledo, Spain  
Phone: +34 925 53 45 00  
Fax: +34 925 51 16 00

### Worldwide Sales Headquarters

Unit 2 Harvington Business Park  
Brampton Road  
Hampden Park Industrial Estate  
Eastbourne East Sussex, BN22 9BN  
United Kingdom  
Phone: +44 (0)1323 452125

All information provided is subject to change without notice.

© 2014 Sundyne, LLC  
All Rights Reserved. Other logos and trade names are property of their respective owners.

Sundyne HMD Kontro  
GSA/GSI F0 3.0 8/16 A4 Eng.