

ZeroLoss™ Containment Shells

HMD Kontro

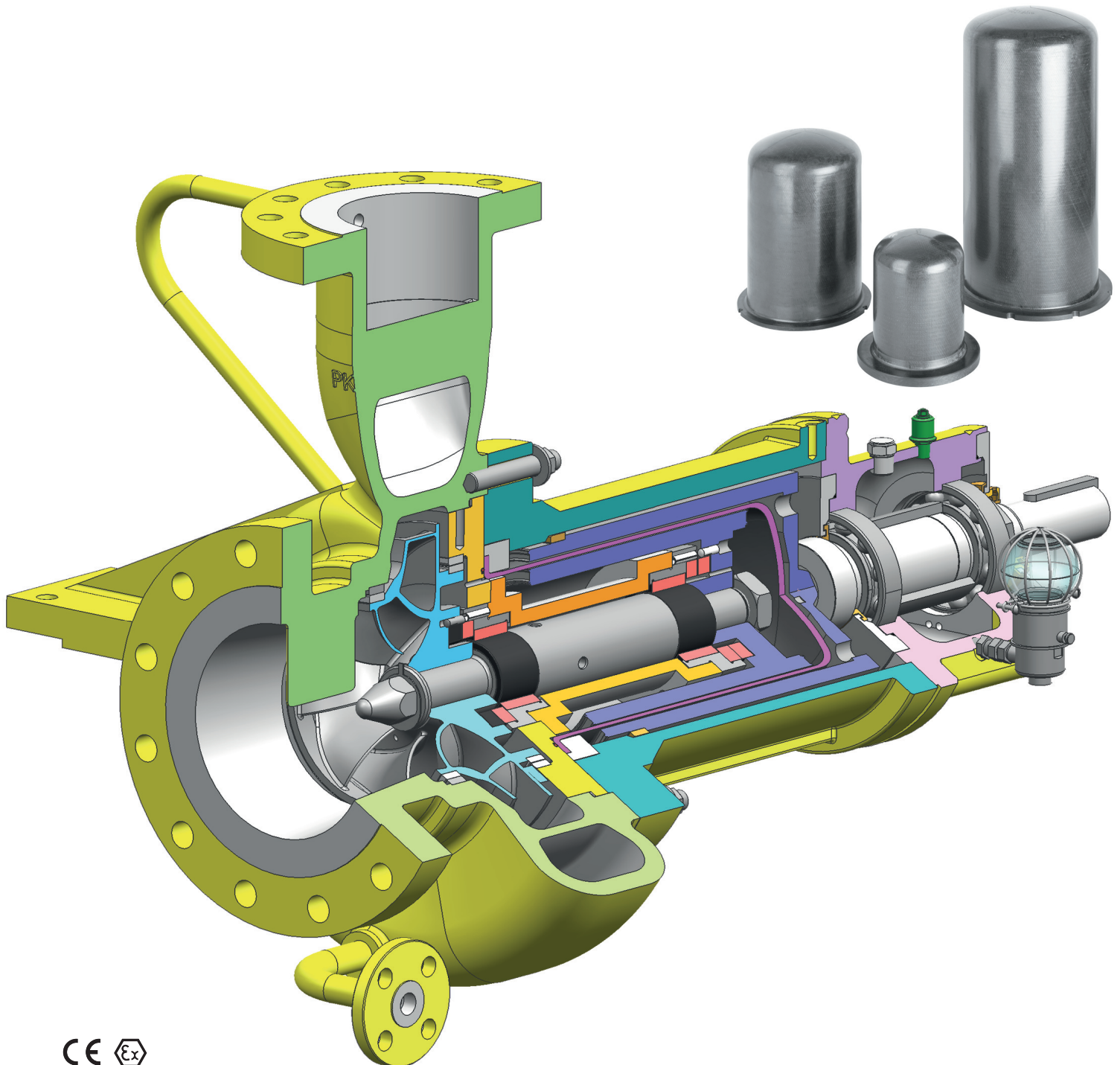



Eddy Current Elimination

The elimination of induced eddy current losses gives the ZeroLoss™ containment shell its name. Heat dissipation can be an issue with magnetic drive pumps and the composite ZeroLoss™ shell provides a step change to this problem by eliminating inductive heating.

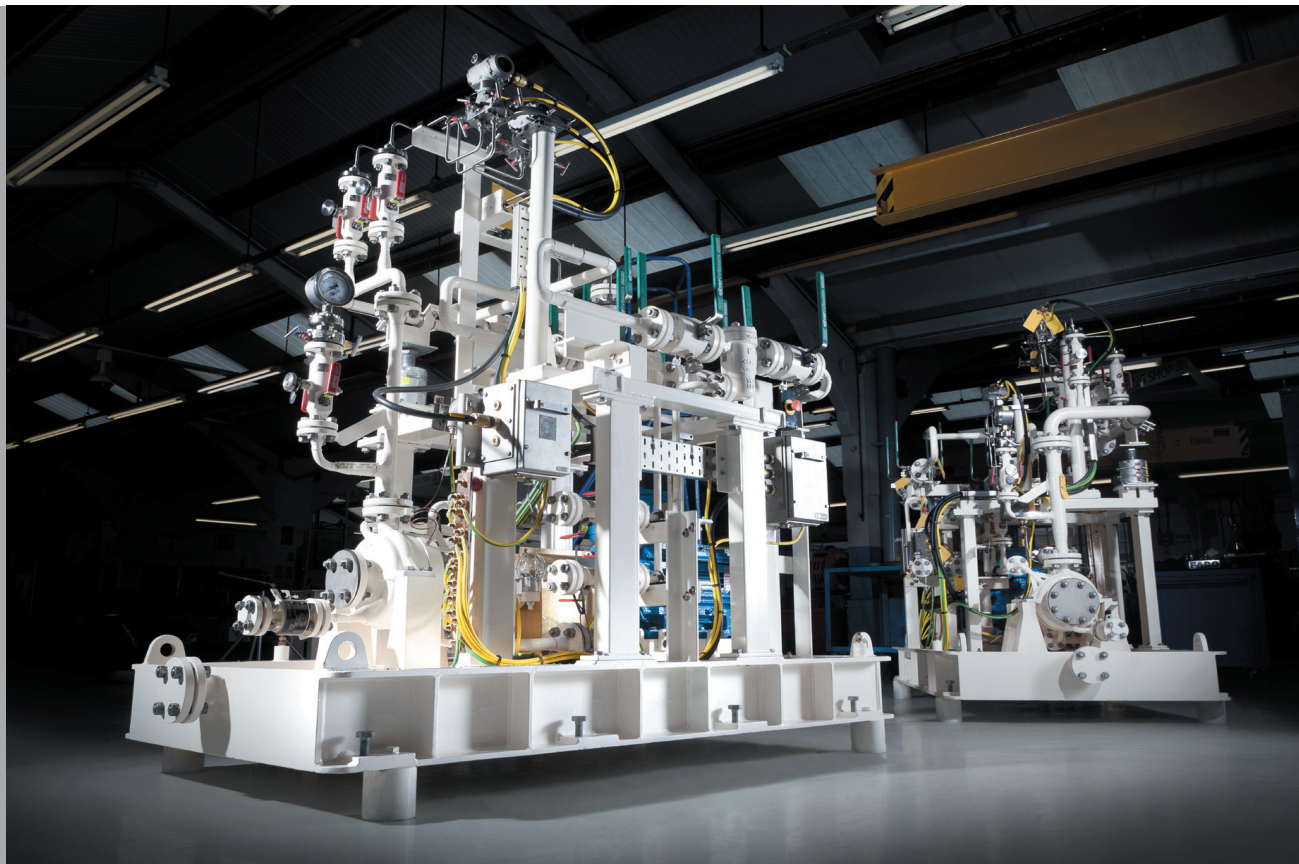

This significantly increases the margin-to-flash safety factor and is particularly important when pumping volatile and heat sensitive liquids.

Five times lighter than steel but as strong, the ZeroLoss™ shell is engineered from a composite material of poly-ether-ether-ketone (PEEK) and carbon fibers. In addition to its higher specific strength, the material is tough and durable.

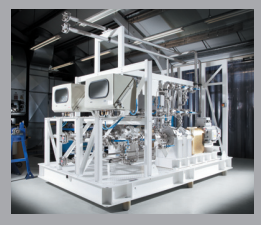

Some Benefits of the ZeroLoss™ Shell

- More robust design for closed discharge or potential dry run circumstances.
- Reduced power consumption for significant energy savings.
- Potentially lower capital costs from smaller motor and magnetic coupling.
- Lower utility costs, both for installation and ongoing consumption.
- Reduced heat into the liquid being pumped.
- Improved handling of liquefied gases and heat sensitive liquids.
- May be retrofitted to existing Sundyne HMD Kontro GSP pumps.

Reduction in Energy Consumption

The ZeroLoss™ containment shell eliminates eddy current losses within the pump. The advantage increases in proportion with the magnetic coupling size and is particularly appropriate for larger pumps, making the magnetic drive option even more attractive because life cycle costs are reduced even further.

Lower power consumption not only results in reduced running costs but also potentially provides lower initial capital costs, as smaller motors can be specified. Also installation costs can be reduced, as lower-rated cabling may be required.

You will also be reducing your carbon footprint, further enhancing the environmental benefits of adopting sealless pumps.

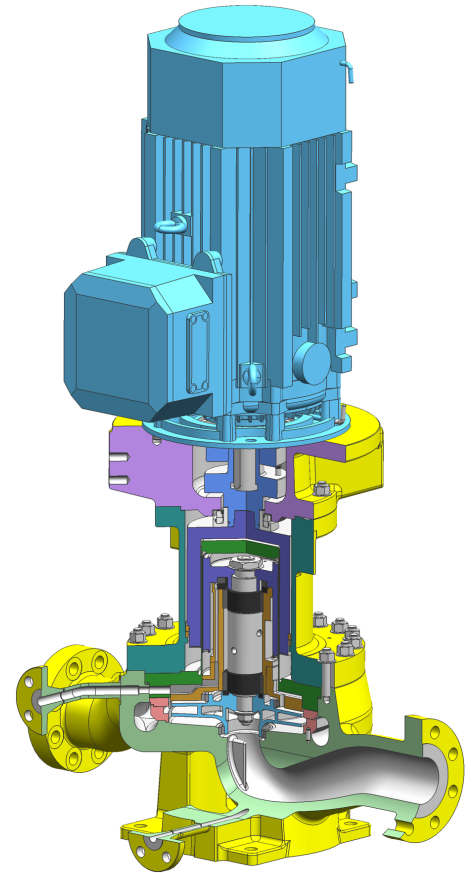

Composite Material for PEEK Performance

The Sundyne HMD Kontro ZeroLoss™ containment shell is engineered from a combination of Carbon Fiber and PEEK (Poly Ether Ether Ketone).

Some of the benefits of this material include the following:

- High tensile strength
- High electrical resistivity
- Chemical resistant
- Excellent fatigue properties
- Fire and heat resistant
- Resistant to thermal shock
- Single part complex shapes
- Recyclable
- No porosity
- Impact resistant
- Thin wall structures
- Low mass
- Low co-efficient of thermal expansion

All of the above properties make the material very suited for use in sealless pumps and in the majority of process applications.



Applicable to Pump Ranges

(limited for operation up to 250°F)

GSA/GSI Frames 1 & 2	GSP Frames 1, 2 & 3	GSPV Frames 1 & 2
GSPVS Frames 1 & 2	GSPLF Frame 2	LMV-801S

ZeroLoss™ Sealless Pumps Parameters

Temperature	-150°F to 250°F / -100°C to 120°C
Flow Rates	8800 USgpm / Up to 2000m ³ /h
Heads	Up to 1140ft differential / 350m
Viscosity	Maximum 200cP
Pressure	Up to 580 psi / 40 bar
Solids	Up to 5% wwt, with a particle size of 150 microns Up to 8% wwt and 500 microns with filtration
Power	440kW 60Hz / 365kW 50Hz
Standards	API685 (API610) / ASME B73.3



Environmentally
Friendly



Strong &
Robust



High
Temperatures



Money
Saving



Energy
Efficient



High
Pressures

Sundyne Headquarters:
Sundyne, LLC
14845 West 64th Avenue
Arvada, Colorado 80007
USA
1-866-Sundyne
Phone: 1 303 425 0800
Fax: 1 303 940 2911
www.sundyne.com

Sundyne United Kingdom
Sundyne HMD Kontro Sealless Pumps
Marshall Road
Hampden Park Industrial Estate
Eastbourne East Sussex, BN22 9AN
United Kingdom
Phone: +44 1323 452000
Fax: +44 1323 503369

Sundyne China:
**Sundyne Industrial Equipment
(Tianjin) Company Limited**
Building 1, No. 879 Shen Fu Road
XinZhuang Industrial Zone
Min Hang District
Shanghai, China 201108
Phone: +86 21 5055 5005
Fax: +86 21 5442 5265

Sundyne France:
Sundyne International S.A.
13-15, Bld. Eiffel - B.P. 30
21604 Longvic Cedex
France
Phone: +33 (0)3 80 38 33 00
Fax: +33 (0)3 80 38 33 66

Sundyne Spain:
Sundyne Marelli Bombas, S.R.L.
Ctra. Madrid-Toledo, Km.30.8
45200 Illescas
Toledo, Spain
Phone: +34 925 53 45 00
Fax: +34 925 51 16 00

All information provided is
subject to change without notice.

© 2015 Sundyne, LLC
All Rights Reserved. Other logos
and trade names are property of
their respective owners.

Sundyne HMD Kontro
ZeroLoss 2.0 08/16 AM Letter