

Technical Profile

LMV-801S

Vertical, low flow, sealless magnetic drive pumps to API 685

The LMV-801S range comprises pumps based on the HMD Kontro GS drive, built to API 685 specification, suitable for heavy-duty applications.

The LMV-801S combines the proven technologies of Sundyne Barske Wheel hydraulics with the HMD Kontro sealless magnetic drive, optimising reliability and efficiency to ensure trouble-free plant operation. The LMV-801S meets the requirements of API 685 and is explosive atmosphere compliant, making it ideal for oil and gas installations plus chemical and petrochemical applications.

An additional advantage of the LMV-801S is the flexibility inherent in the diffuser and impeller, which can easily be upgraded should the duty need to be changed without replacing the pressure casing.

Sealed to Sealless

The LMV-801S pump is dimensionally interchangeable with the LMV 801 mechanical seal pump and will simply 'drop-in' to existing client pipework, making sealless upgrades possible without the need to modify pipe and foundation layout.

A 'plug-in' version of the pump is also available. This enables the client to leave his existing LMV 801 casing and diffuser in the pipe line whilst replacing the mechanical seal drive end with a sealless drive end that will simply 'plug-in' to the existing casing.

Performance of the LMV-801S

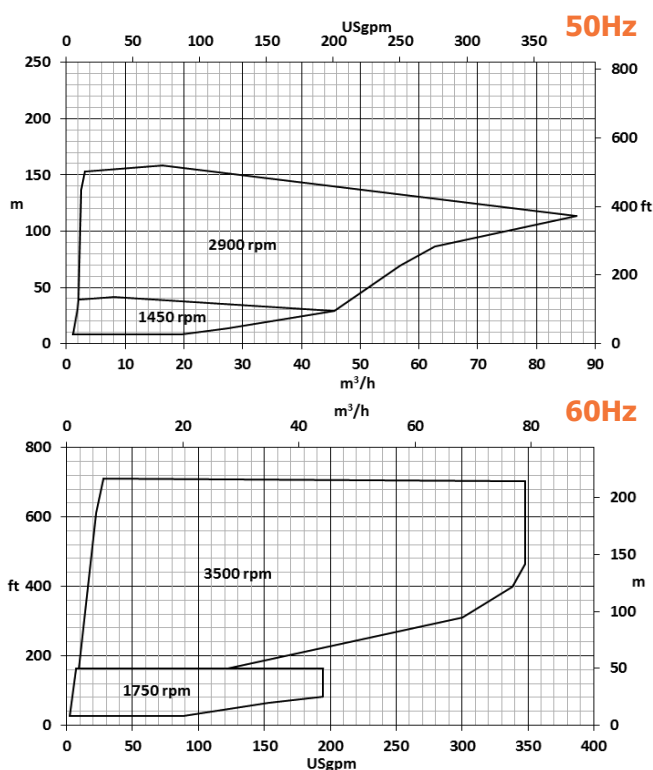

HMD Kontro

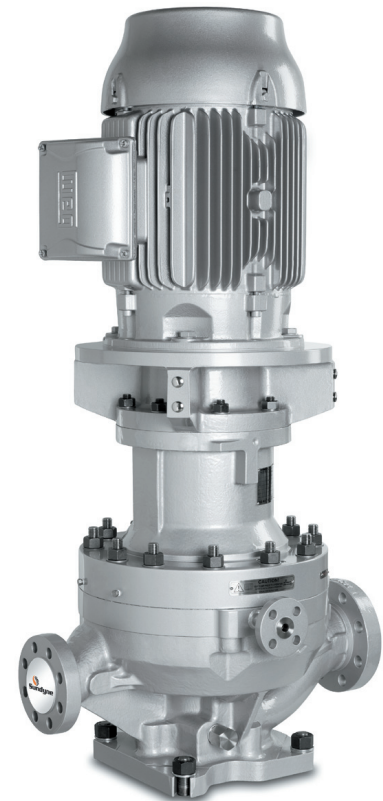

Design range limits

The LMV 801S pump is designed to operate from -40°C up to 205°C / -40°F up to 400°F without the need for any ancillary cooling medium. Design working pressure is 40 bar / 580 psi at ambient temperature.

Solids handling

The unit is designed for use on clean liquids only. However, a small amount of solids in the liquid is acceptable depending on size and type. Check with Sundyne Technical if in doubt.

Materials of construction

Standard S-5, A-8, D-1 and D-2
Other variations available on request

Options

- High Efficiency ZeroLoss™ Containment Shell
- Secondary Control System
- Secondary Containment System
- Inducers
- NACE Compliant Materials
- Horizontal end suction derivative
- High system pressure derivatives (100 bar)

Key Design Features

- Conforms to API 685 Standard for Sealless Pumps
- No mechanical seal system required
- Material options available
- Optional ZeroLoss™ composite containment shell technology
- Secondary sealing options for highly hazardous liquids
- Cartridge replacement

Motors

Motor power transmission
IEC V1 D flange mounted
NEMA C flange mounted

Benefits

- Internationally recognised standard for heavy duty pumps in petroleum, petrochemical, and gas industry process service
- Reduced cost of installation
- Reduced cost of maintenance
- Reduced risk of operational error
- Leak free operation
- Environmentally safe
- Standard range of materials according to API 685 material classes
- Standard material options are suitable for a large range of corrosive liquids
- Other materials available by request
- High efficiency magnet drive
- Greatly reduces chance of liquid 'flashing' during process upset conditions
- Ideal for liquids with low specific heat or liquids near their boiling point
- Secondary control option minimises leakage if primary containment shell is breached
- Secondary containment option prevents leakage if primary containment shell is breached
- Greatly reduced down time for maintenance
- Reduced spare parts inventory and associated costs

Construction of LMV-801S Pumps

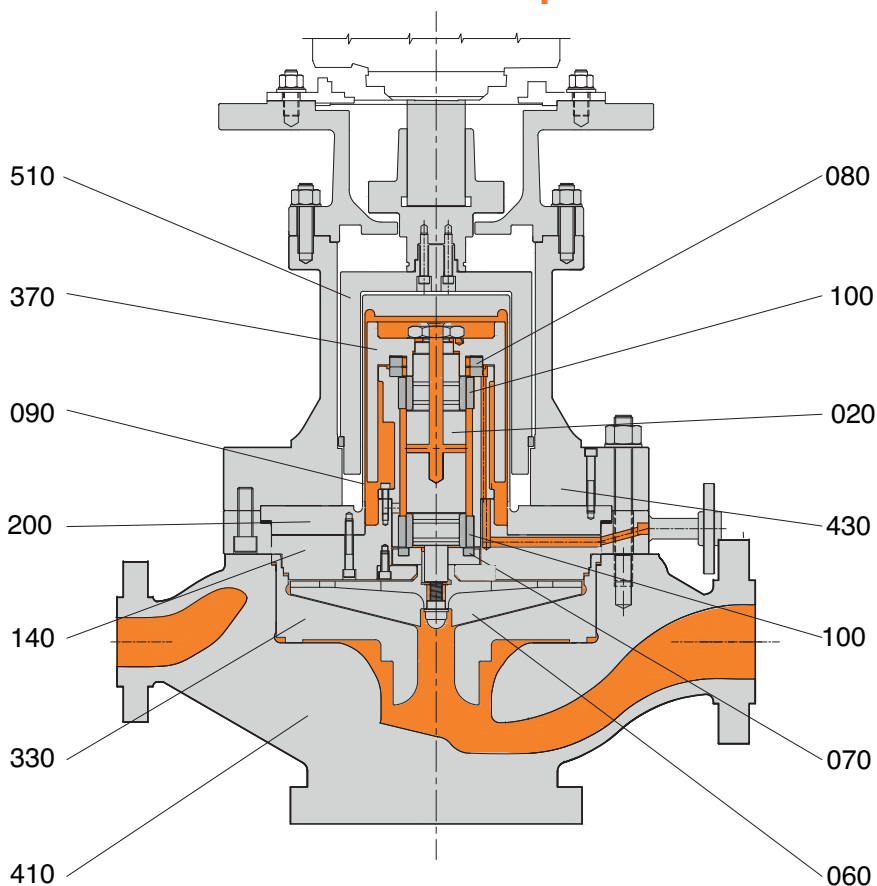

020	Pump Shaft
060	Impeller
070	Thrust Washer (Front)
080	Thrust Washer (Back)
090	Bush Holder
100	Bush
140	Casing Plate
200	Shroud
330	Diffuser
370	Inner Magnet Ring
410	Casing
430	Coupling Housing
510	Outer Magnet Ring

Flanges and Connections

Casing

Suction and discharge flanges are designed in accordance with the following relevant standards:

ANSI B16.5 Class 600 Machined with 7mm (1/4") high raised face having a continuous spiral groove

Flange Loadings

Allowable flange loadings imposed by pipework are in accordance with Table 4 of API 685 2nd edition.

Drain and Vent Connections

The following drain and vent options are available:

Standard: Socket weld flange

Optional: NPT plug

Dimensions of a typical LMV-801S pump

Dimensions are for guidance only. Do not use for installation purposes.

PUMP CONNECTIONS		
N1	SUCTION	3" ANSI 6001b
N2	DISCHARGE	2" ANSI 6001b
N3	CASING DRAIN	1" ANSI 6001b
N4	CASING VENT	1/2" ANSI 6001b

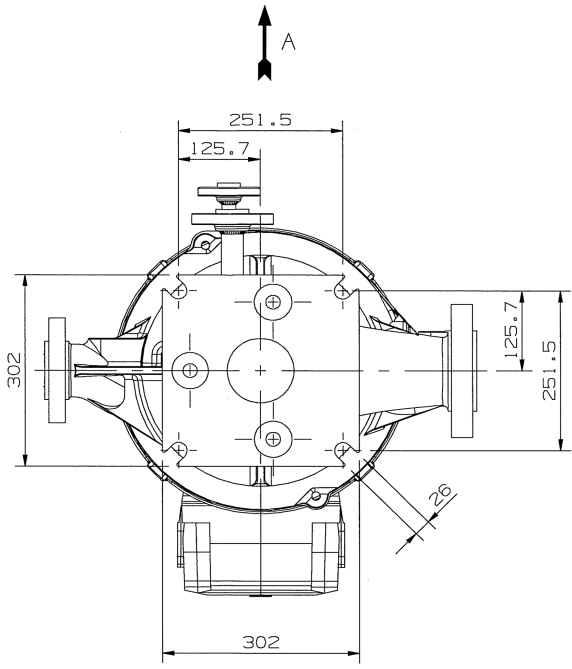
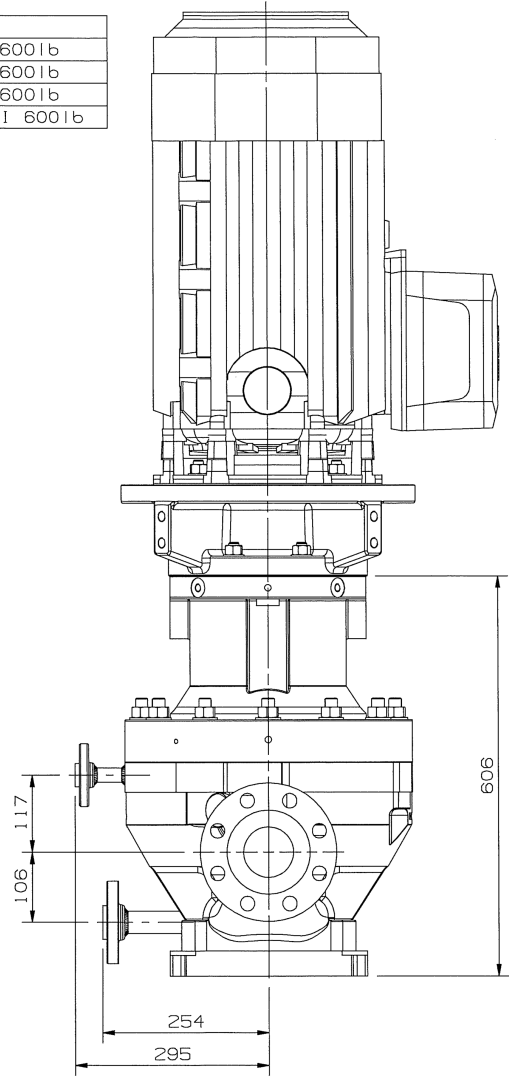
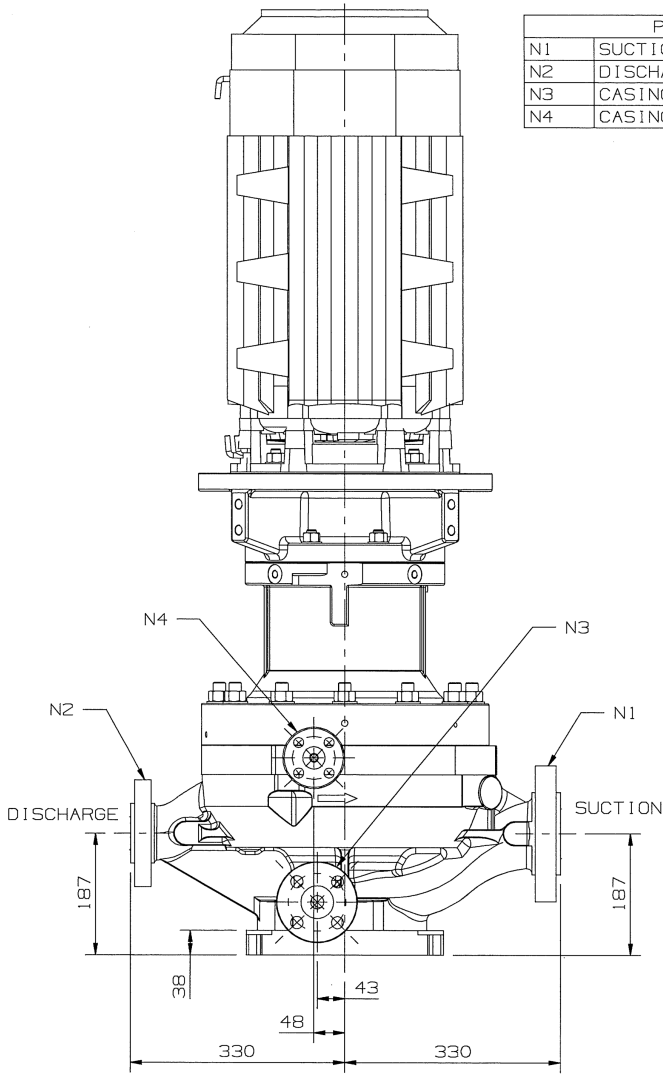

	mm	inches
A	187	7.4
B	187	7.4
C	330	13.0
D	330	13.0
E	48	1.9
F	43	1.7
G	302	11.9
H	117	4.6
I	106	4.2
J	254	10.0
K	295	11.6
L	606	23.9

Range Capabilities

Frequency	Head	Flow	Design Temperature	Design Pressure
50Hz	150m	4 to 71 m ³ /h	-40 to 205°C	40 bar
60Hz	720ft	20 to 380 USgpm	-40 to 400°F	580 psi

Note: the tabulated dimensions are for guidance only.

Pressure limits

All parts are to be rated to the pressures shown below at 38°C / 100°F

Flange standard	Design pressure			
	S-5	A-8	D-1	D-2
ANSI B16.5	4.0 MPa	4.0 MPa	4.0 MPa	4.0 MPa
Class 600	580 psi	580 psi	580 psi	580 psi

Component	Hydrostatic test values			
	S-5	A-8	D-1	D-2
Casing	6.0 MPa	6.0 MPa	6.0 MPa	6.0 MPa
Class 600	870 psi	870 psi	870 psi	870 psi
Containment Shell	6.0 MPa	6.0 MPa	6.0 MPa	6.0 MPa
Class 600	870 psi	870 psi	870 psi	870 psi

Temperature limits

	S-5	A-8	D-1	D-2
	-29°C to 205°C (-20°F to 400°F)	-100°C to 205°C (-148°F to 400°F)	-40°C to 205°C (-40°F to 400°F)	-40°C to 205°C (-40°F to 400°F)

Sundyne Headquarters:

Sundyne, LLC

14845 West 64th Avenue
Arvada, Colorado 80007
USA
1-866-Sundyne
Phone: 1 303 425 0800
Fax: 1 303 940 2911
www.sundyne.com

Sundyne United Kingdom:

Sundyne HMD Kontro Sealless Pumps

Marshall Road
Hampden Park Industrial Estate
Eastbourne, East Sussex, BN22 9AN
United Kingdom
Phone: +44 (0)1323 452000
Fax: +44 (0)1323 503369

Sundyne China:

Sundyne Industrial Equipment (Tianjin) Company Limited

Building 1, No. 879 Shen Fu Road
XinZhuang Industrial Zone
Min Hang District
Shanghai, China 201108
Phone: +86 21 5055 5005
Fax: +86 21 5442 5265

Sundyne France:

Sundyne International S.A.

13-15, Bld. Eiffel - B.P. 30
21604 Longvic Cedex
France
Phone: +33 (0)3 80 38 33 00
Fax: +33 (0)3 80 38 33 66

Sundyne Spain:

Sundyne Marelli Bombas, S.R.L.

Ctra. Madrid-Toledo, Km.30.8
45200 Illescas
Toledo, Spain
Phone: +34 925 53 45 00
Fax: +34 925 51 16 00

Worldwide Sales Headquarters

Unit 2 Harvington Business Park
Brampton Road
Hampden Park Industrial Estate
Eastbourne East Sussex, BN22 9BN
United Kingdom
Phone: +44 (0)1323 452125

All information provided is subject to change without notice.

© 2014 Sundyne, LLC
All Rights Reserved. Other logos and trade names are property of their respective owners.

Sundyne HMD Kontro
LMV-801S 1.0 11/14 A4 Eng.