

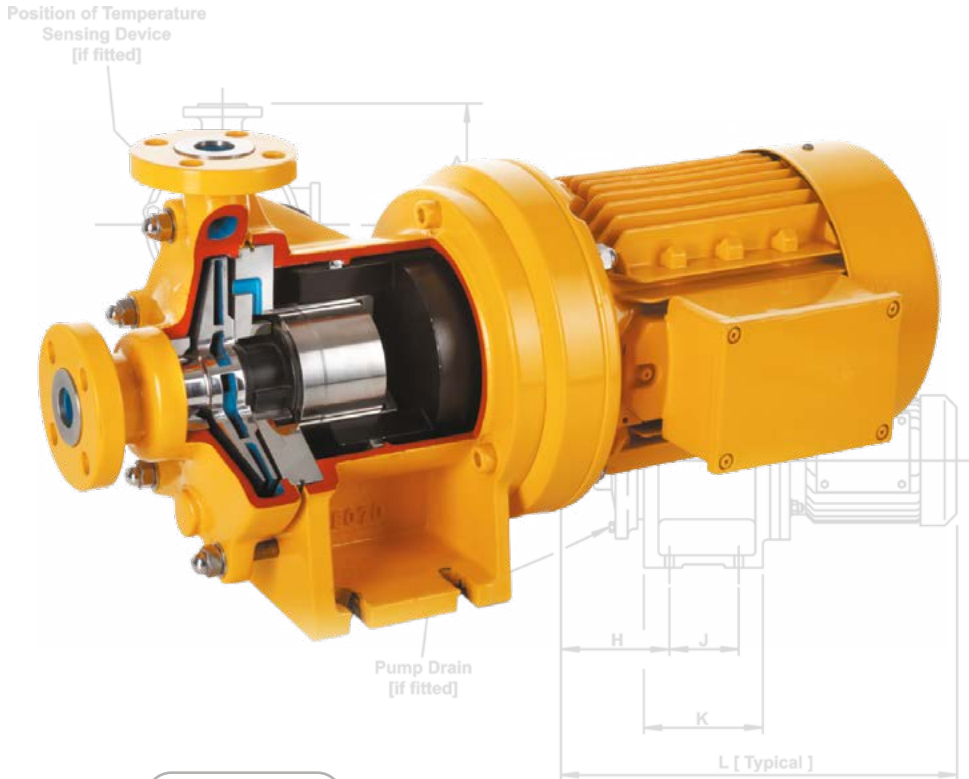

The GT (Sub ASME / ISO) range comprises sealless magnetic drive end suction centrifugal pumps for general chemical transfer applications.

GT (SUB ASME / ISO)



For general transfer duties, the **GT** pump has been specifically designed as a compact, cost-effective and minimum maintenance pump. The GT is sized below ASME / ISO dimensions and has a number of features, which make it one of the most highly competitive pumps in its class. Thanks to its simplicity of maintenance, space-saving design and interchangeability, the GT pump proves a very popular choice.

GT pumps are of a close coupled construction and can be supplied free standing or baseplate mounted. Prime mover specifications of all denominations can be catered for with a range of Synchronous Magnet Drives rated to match.

Specifications

	60Hz	50Hz
Heads	10 to 190ft	2 to 41m
Flows	4 to 163gpm	1 to 30m ³ /hr
Max Power	15 hp	11 KW
Temp Range	-40 to 500°F	-40 to 260°C
Number of Stages	1	
Max Case Working Pressure	275 psi	18.9 bar
Max Suction Pressure	275psi (18.9 bar)	
Differential Head	190 ft	58 m
Standard Delivery	Stock to 4 weeks	
Speed Range	1,450 to 3,500rpm	
Materials of Construction	316 SS, Alloy 20, Alloy B2	
Bearing Materials Available	Alfa sintered SiC	
Hydrotest Pressure	412 psi	28 bar
Max Viscosity	200 cSt	
Solids Range	Maximum of 5% w/w less than 150 microns	
Motor Details	Industry standard	

APPLICATIONS

Ideal for a wide range of general transfer applications within the chemical, pharmaceutical and refining industries.

CONSTRUCTION

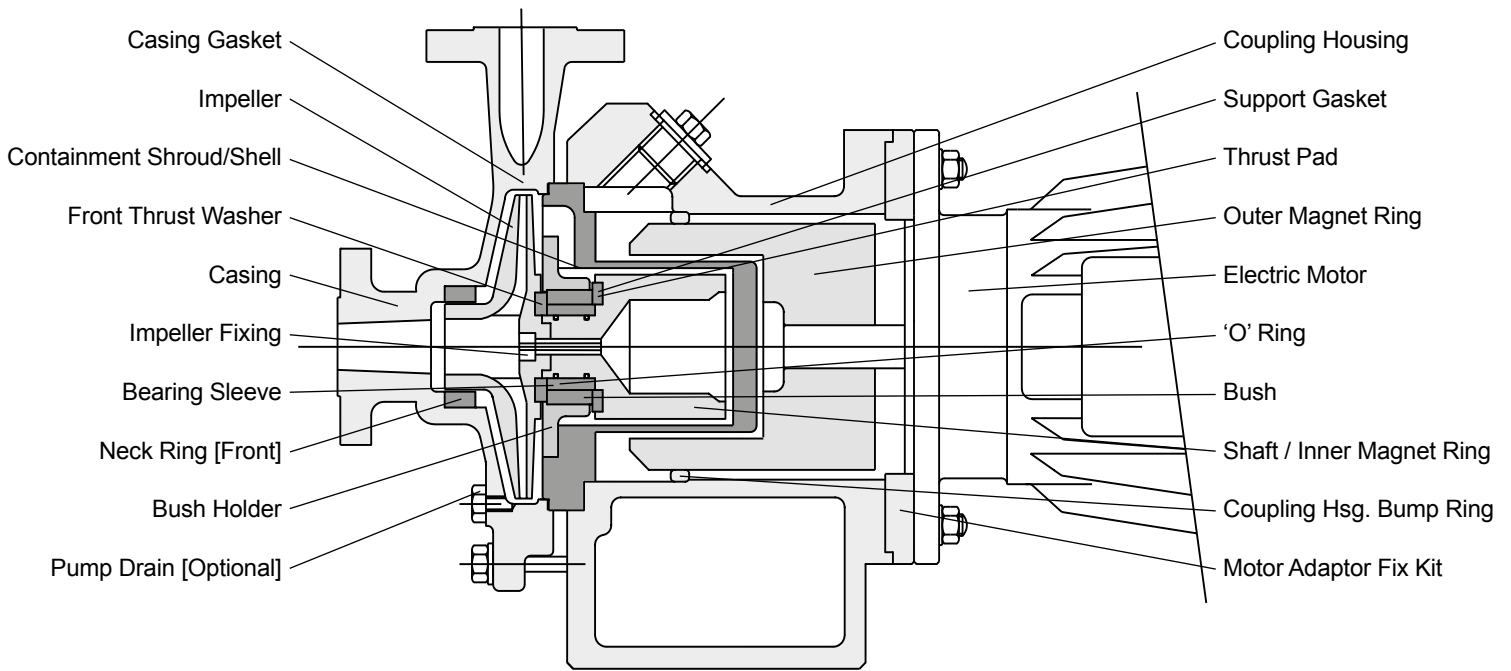

PERFORMANCE

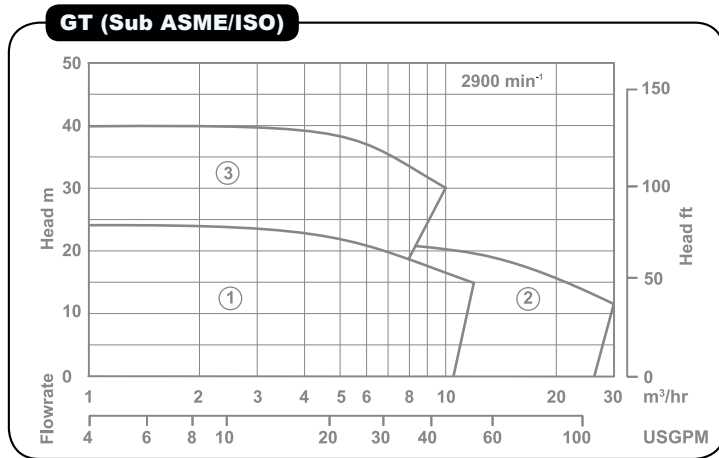

Visit our website at: www.sundyne.com

Sundyne Headquarters: Sundyne, LLC 14845 W. 64th Ave. Arvada, CO 80007 USA 1-866-SUNDYNE (US and Canada) Ph: +1 303 425 0800 Fax: +1 303 425 0896

Sundyne United Kingdom: Sundyne HMD Kontro Sealless Pumps, Ltd. Marshall Rd, Hampden Park Industrial Estate, Eastbourne, East Sussex, BN22 9AN UK Ph: +44 1323 452000 Fax: +44 1323 503369

Sundyne China: Bldg. 1, No. 879 Shen Fu Road, XinZhuang Industrial Zone, Min Hang District, Shanghai, China 201108 Ph: +86 21 6121 1600 Fax: +86 21 5442 5266

Sundyne France: Sundyne International S.A. 13-15, Bld. Eiffel - B.P. 30 21604 Longvic Cedex France Ph: +33 (0)3 80 38 33 00 Fax: +33 (0)3 80 38 33 66

Sundyne Spain: Sundyne Marelli Bombas, S.R.L. Ctra. Madrid-Toledo, Km.30.8 45200 Illescas Toledo, Spain Ph: +34 925 53 45 00 Fax: +34 925 51 16 00

© 2017 Sundyne, LLC All rights reserved. Other logos and trade names are property of their respective owners. GT (Sub ASME/ISO)_TDS_AM_v1.0_01.04.17