

CS Torque Ring Upgrade

For the Outer Magnet Ring (OMR) on HMD Kontro pumps

The new generation of outer magnet ring (OMR) for the asynchronous CS Torque Ring pump range, offers a step change in magnetic coupling robustness.

The retrofitable OMR provides the following benefits:

- More robust design solution and optimised MTBF.
- Shielded magnets retaining performance and eliminating the potential for damage.
- Improved cyclic thermal duty performance.
- Identical coupling power to OMR being replaced, minimising the limit of the change.
- Increase in CS pump Mean Time Between Failure (MTBF) reducing downtime and increasing operational efficiency.
- Increased Resistance to corrosive applications.

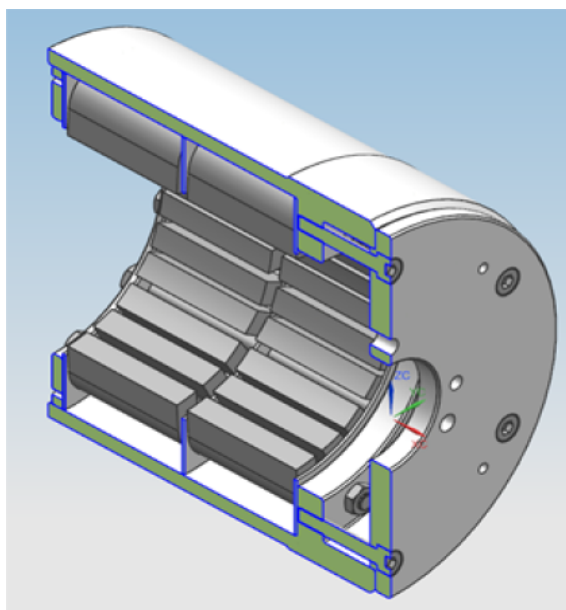
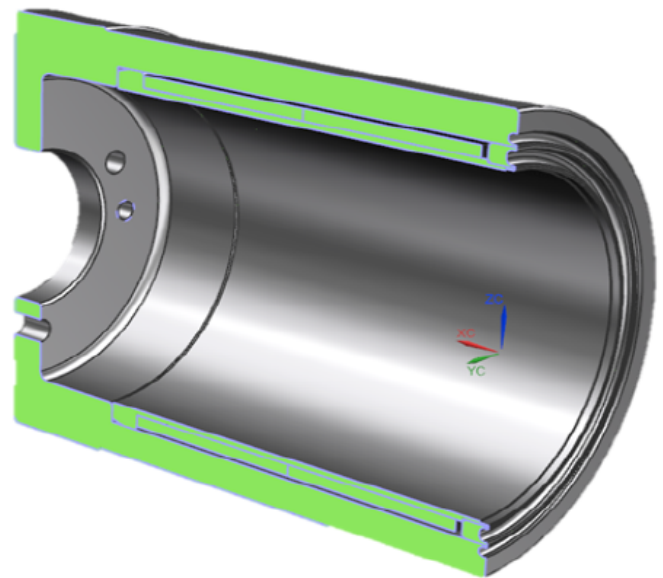

Key Benefits of the OMR Upgrade:

- More robust than the Original Alcomax design, leading to increased MTBF.
- Magnets used are significantly more powerful and give a constant output performance.
- Reduced delivery due to standardisation of components including magnets.
- Upgrade is completed quickly and easily on-site.
- No special tools required for upgrade or maintenance.

Suitable for:

- HMD Kontro CS1C, CS1D, CS2D, CS2E, CS3E, CS3F & CS4F pumps.
- Pumps with original Alcomax OMR fitted.
- High temperature applications 350Deg C /660Deg F.

Upgrade includes:

- Outer magnet ring fitted with Samarium Cobalt Magnets that are sheathed as standard.

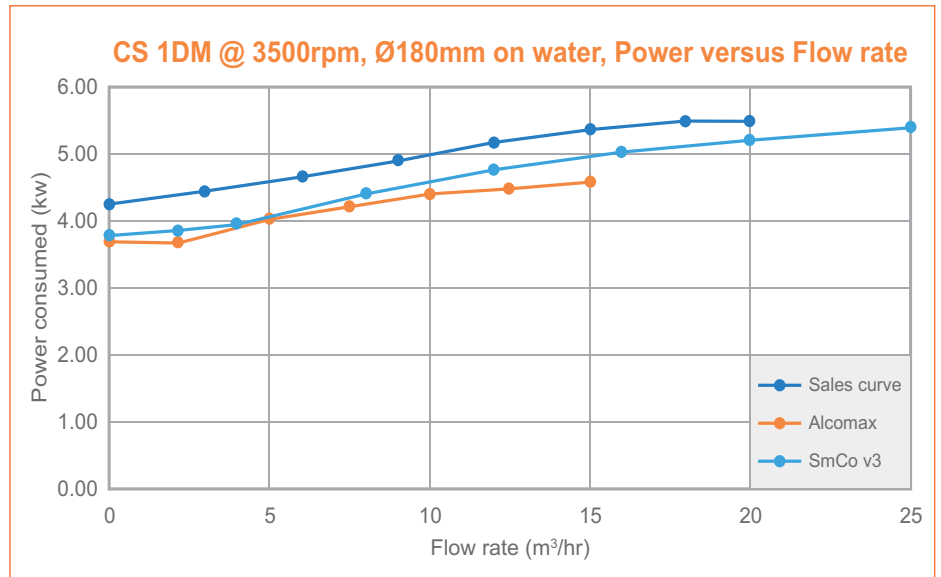

| Original OMR Design Using Alcomax (Unsheathed) | | | Original Design with Increased Performance Rare Earth 10 (Sheathed) | | | New Upgrade Version 2019 Using Samarium Cobalt SMC0 26H (Sheathed) | | |
|--|---------|---|---|---------|---|--|------------|---|
| OMR Size | Part NO | Material/Magets | OMR Size | Part NO | Material/Magets | OMR Size | Part NO | Material/Magets |
| CS1C | CS1C51A | 316SiSt ASTM A351 CF8M - Body Tie Bolts - 314SiSt Lock Ring - Aluminium BS1470SIC 0 Drive Flange - Carbon Steel BSEN 10025 S275JR Magnets - Alcomax | CS1C-RE | CS1C51G | Carbon Steel BS970 070 M20- Body 304LSiSt DIN 17456 1.4306 - Core 304LSiSt DIN 17456 1.430 - Magnet Shield Magnets - Samarium Cobalt Rare Earth 10 (Square Type) | CS1C | CS1C51A-RE | Carbon Steel BS 970 070 M20 - Body 304LSiSt BS EN 10088-3 1.4307 - Core 304LSiSt BS EN 10088-3 1.4307 - Magnet Shield Magnets - Samarium Cobalt Rare Earth (Slab Type) |
| CS1D | CS1D51A | 316SiSt ASTM A351 CF8M - Body Tie Bolts - 314SiSt Lock Ring - Aluminium BS1470SIC 0 Drive Flange - Carbon Steel BSEN 10025 S275JR Magnets - Alcomax | CS1D-RE | CS1D51J | Carbon Steel BS970 070 M20- Body 304LSiSt DIN 17456 1.4306 - Core 304LSiSt DIN 17456 1.430 - Magnet Shield Magnets - Samarium Cobalt Rare Earth 10 (Square Type) | CS1D | CS1D51A-RE | Carbon Steel BS 970 070 M20 - Body 304LSiSt BS EN 10088-3 1.4307 - Core 304LSiSt BS EN 10088-3 1.4307 - Magnet Shield Magnets - Samarium Cobalt Rare Earth (Slab Type) |
| CS2D | CS2D51A | 316SiSt ASTM A351 CF8M - Body Tie Bolts - 314SiSt Lock Ring - Aluminium BS1470SIC 0 Drive Flange - Carbon Steel BSEN 10025 S275JR Magnets - Alcomax | CS2D-RE | CS2D51J | Carbon Steel BS970 070 M20- Body 304LSiSt DIN 17456 1.4306 - Core 304LSiSt DIN 17456 1.430 - Magnet Shield Magnets - Samarium Cobalt Rare Earth 10 (Square Type) | CS2D | CS2D51A-RE | Carbon Steel BS 970 070 M20 - Body 304LSiSt BS EN 10088-3 1.4307 - Core 304LSiSt BS EN 10088-3 1.4307 - Magnet Shield Magnets - Samarium Cobalt Rare Earth (Slab Type) |
| CS2E | CS2E51Q | 316SiSt ASTM A351 CF8M - Body Tie Bolts - 314SiSt Lock Ring - Aluminium BS1470SIC 0 Drive Flange - Carbon Steel BSEN 10025 S275JR Magnets - Alcomax | CS2E-RE | CS2E51J | Carbon Steel BS970 070 M20- Body 304LSiSt DIN 17456 1.4306 - Core 304LSiSt DIN 17456 1.430 - Magnet Shield Magnets - Samarium Cobalt Rare Earth 10 (Square Type) | CS2E | CS2E51Q-RE | Carbon Steel BS 970 070 M20 - Body 304LSiSt BS EN 10088-3 1.4307 - Core 304LSiSt BS EN 10088-3 1.4307 - Magnet Shield Magnets - Samarium Cobalt Rare Earth (Slab Type) |
| CS3E | CS3E51Q | 316SiSt ASTM A351 CF8M - Body Tie Bolts - 314SiSt Lock Ring - Aluminium BS1470SIC 0 Drive Flange - Carbon Steel BSEN 10025 S275JR Magnets - Alcomax | CS3E-RE | CS3E51J | Carbon Steel BS970 070 M20- Body 304LSiSt DIN 17456 1.4306 - Core 304LSiSt DIN 17456 1.430 - Magnet Shield Magnets - Samarium Cobalt Rare Earth 10 (Square Type) | CS3E | CS3E51Q-RE | Carbon Steel BS 970 070 M20 - Body 304LSiSt BS EN 10088-3 1.4307 - Core 304LSiSt BS EN 10088-3 1.4307 - Magnet Shield Magnets - Samarium Cobalt Rare Earth (Slab Type) |
| CS3F | CS3F51A | 316SiSt ASTM A351 CF8M - Body Tie Bolts - 314SiSt Lock Ring - Aluminium BS1470SIC 0 Drive Flange - Carbon Steel BSEN 10025 S275JR Magnets - Alcomax | CS3F-RE | CS3F51J | Carbon Steel BS970 070 M20- Body 304LSiSt DIN 17456 1.4306 - Core 304LSiSt DIN 17456 1.430 - Magnet Shield Magnets - Samarium Cobalt Rare Earth 10 (Square Type) | CS3F | CS3F51A-RE | Carbon Steel BS 970 070 M20 - Body 304LSiSt BS EN 10088-3 1.4307 - Core 304LSiSt BS EN 10088-3 1.4307 - Magnet Shield Magnets - Samarium Cobalt Rare Earth (Slab Type) |
| CS4F | CS4F51A | 316SiSt ASTM A351 CF8M - Body Tie Bolts - 314SiSt Lock Ring - Aluminium BS1470SIC 0 Drive Flange - Carbon Steel BSEN 10025 S275JR Magnets - Alcomax | CS4F-RE | CS4F51J | Carbon Steel BS970 070 M20- Body 304LSiSt DIN 17456 1.4306 - Core 304LSiSt DIN 17456 1.430 - Magnet Shield Magnets - Samarium Cobalt Rare Earth 10 (Square Type) | CS4F | CS4F51A-RE | Carbon Steel BS 970 070 M20 - Body 304LSiSt BS EN 10088-3 1.4307 - Core 304LSiSt BS EN 10088-3 1.4307 - Magnet Shield Magnets - Samarium Cobalt Rare Earth (Slab Type) |

Note: CSE & CSF OMR's are currently undergoing testing

To maximise your uptime, please contact HMD Kontro's highly skilled Aftersales Technical Support Team who have vast experience in the operational aspects that customers may encounter during the lifetime of their sealless pump installations. We are keen to share this knowledge with you to ensure your pump maintenance is optimised and straightforward, fast and cost effective. Our Engineers are always on hand to provide trouble shooting advice and to recommend suitable upgrades, spares kits and stock inventory levels.

Tel: +44 (0)1323 452154. Out of hours +44 (0)7789 171645

Email: hmdparts@sundyne.com